

# **SPECIFICATIONS, PROPOSAL AND CONTRACT DOCUMENTS**

FOR

**FY 2023 RAA STREET RESURFACING AND REPAIRS  
REBUILD ALABAMA ACT (RAA) ANNUAL GRANT PROGRAM**

PREPARED FOR:

**CITY OF JACKSON**

JANUARY 2024



**SPECIFICATIONS**

**PROPOSAL AND CONTRACT DOCUMENTS**

**FY 2023 RAA STREET RESURFACING AND REPAIRS  
REBUILD ALABAMA ACT (RAA) ANNUAL GRANT PROGRAM**

**CITY OF JACKSON  
JACKSON, ALABAMA**

January 2024

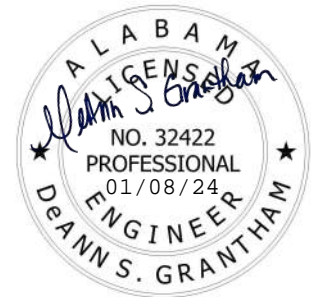

Prepared by:

**SOUTHERN ENGINEERING SOLUTIONS, INC.  
201 EAST TROY STREET  
P.O. BOX 610  
ANDALUSIA, ALABAMA 36420  
(334) 222-1849**

## TABLE OF CONTENTS

	PAGE
ADVERTISEMENT FOR BIDS.....	1
INFORMATION FOR BIDDERS .....	2
BID BOND .....	6
PROPOSAL.....	8
AGREEMENT.....	12
PAYMENT BOND .....	15
PERFORMANCE BOND.....	17
NOTICE OF AWARD .....	19
NOTICE TO PROCEED .....	20
CHANGE ORDER .....	21
CERTIFICATION BY OWNER .....	22
GENERAL CONDITIONS.....	23
SUPPLEMENTAL GENERAL CONDITIONS.....	37
SPECIAL SPECIFICATIONS .....	42
GENERAL SPECIFICATIONS FOR STORMWATER DRAINAGE.....	54
GENERAL SPECIFICATIONS FOR EXCAVATION BACKFILL AND COMPACTION FOR UTILITIES .....	60

## ADVERTISEMENT FOR BIDS

Sealed bids for the construction of **FY 2023 RAA STREET RESURFACING AND REPAIRS** in Jackson, Alabama will be received by the **City of Jackson** in the meeting room at the City Hall until **9:00 AM, Thursday, January 18, 2024**, and then at said location publicly opened and read aloud.

The work under the Base Bid generally consists of approximately 4,300 tons of asphalt resurfacing and miscellaneous drainage improvements.

The information for Bidders, Form of Bid, Form of Contract, Plans, Specifications, and form of Bid Bond, Performance and Payment Bond, and other Contract Documents may be examined at the City Hall of Jackson at 400 Commerce Street; Jackson, Alabama 36545 and at the office of Southern Engineering Solutions, Inc., 201 East Troy Street, Andalusia, Alabama, 36420.

To be eligible for consideration, bids must be submitted on complete proposals made available by the Owner. Complete digital project bidding documents are available upon an online payment of a non-refundable fee of \$40.00 by visiting our website - [www.southernengineeringsolutions.com](http://www.southernengineeringsolutions.com) and clicking the "Currently Bidding" link at the top of the page. A free one-time membership registration with Quest CDN will be required. Please contact [questcdn.com](http://questcdn.com) at 952-233-1632 or [info@questcdn.com](mailto:info@questcdn.com) if you require assistance in registration, downloading, or working with this digital project information. Optional complete paper bid documents are available at Southern Engineering Solutions, Inc.; P O Box 610; 201 East Troy Street; Andalusia, Alabama 36420, upon payment of a refundable (if plans are returned in reusable condition within 10 days of bid opening) deposit of \$80.00. Bid documents will be mailed only upon receipt of deposit. If paper option is chosen, checks shall be made payable to Southern Engineering Solutions, Inc. No paper bid documents will be distributed later than 48 hours prior to the scheduled opening of bids.

The Owner reserves the right to reject any or all bids and to waive any informalities.

Each bidder must submit with his bid, security in the amount, form, and subject to the conditions provided in the Information for Bidders. The successful bidder will be required to submit a 100% performance bond and a 50% payment bond.

All bidders must comply with the requirements of the Contractor's Licensing Law of the State of Alabama and be certified for the type of work for which a proposal is submitted. The submission of the Bidders' current State of Alabama license number will be required before his/her bid will be received or considered.

No bidder may withdraw his bid within 30 days after the actual date of the opening thereof.

Paul South  
Mayor  
City of Jackson

## INFORMATION FOR BIDDERS

Bids will be received by the **City of Jackson, Alabama** (herein called the Owner) at **Jackson City Hall, 400 Commerce Street; Jackson, Alabama 36545** until **9:00 a.m., Thursday, January 18, 2024**, and then at said location publicly opened and read aloud.

Delivery of Proposal. Each bid must be submitted in a sealed envelope, addressed to the **City of Jackson; 400 Commerce Street; Jackson, Alabama 36545.**

Each sealed envelope containing a bid must be plainly marked on the outside as "**Bid for FY 2023 RAA Street Resurfacing and Repairs**" and the envelope should bear on the outside the name of the Bidder, his address, his license number and the name of the project for which the bid is submitted. If forwarded by mail, the sealed envelope containing the bid must be enclosed in another envelope addressed to the **City of Jackson, 400 Commerce Street; Jackson, Alabama 36545.**

Preparation of Bid Form. All bids must be made on the required bid form. All blank spaces for bid prices must be filled in, in ink or typewritten, and the bid form must be fully completed and executed when submitted. Only one copy of the bid form is required.

Withdrawal of Bids. Any bid may be withdrawn prior to the above scheduled time for the opening of the bids or authorized postponement thereof, provided a request in writing executed by the Bidder or his duly authorized representative is filed with the Owner prior to that time. Upon receipt and confirmation of such notice, the unopened bid will be promptly returned. Except as provided in the foregoing, no bid may be withdrawn.

General. The Owner may waive any informalities or minor defects or reject any and all bids. Any bid received after the time and date specified shall not be considered. Except for the condition described below, no Bidder may withdraw a bid within 30 days after the actual date of the opening thereof. Should there be reasons why the contract cannot be awarded within the specified period, the time may be extended by mutual agreement between the Owner and the Bidder.

Mistakes. The low bidder may seek withdrawal of his bid without forfeiture by providing written notice to the Owner within three working days after the date of the bid opening by providing convincing evidence he made a mistake in his bid caused by calculation or clerical error, an inadvertent omission, or a typographical error which causing his bid to be substantially out of proportion to that of other bidders. The Owner will make a decision within 10 days of receipt of the bidder's notice, or by the next regular meeting of the awarding authority. In no event shall a mistake of law, judgement, or opinion constitute valid grounds for withdrawal of a bid without forfeiture. Upon withdrawal of bid without forfeiture, the low bidder who withdraws his bid due to a mistake shall not be allowed to participate in any work on the contract in any capacity and shall not be allowed to participate in a rebid of the project.

A conditional or qualified Bid will not be accepted.

Award will be made to the lowest responsible Bidder.

Interpretation of the Quantities in Bid Schedule. Bidders must satisfy themselves of the accuracy of the estimated quantities in the Bid Schedule by examination of the site of the proposed work and a review of the drawings and specifications, including Addenda. After bids have been submitted, the Bidder shall not assert that there was a misunderstanding concerning the quantities of work or of the nature of the work to be done. Although the estimate of quantities of work listed in the Bid Schedule are the results of calculations made from field survey, they are to be considered as only approximate estimates of the quantities of the different pay items and are to be used only as a basis for comparing bids for awarding the contract. Payment to the Contractor will be made only for the actual quantities of work performed in accordance with the plans and specifications. If, upon completion of construction, the actual quantities of work performed under unit price bids shall show either increase or decrease from the quantities shown in the Bid Schedule, the unit prices bid will prevail, except as otherwise provided for herein.

The right is reserved to increase or decrease any or all of the amounts given in the approximate quantities as shown in the Bid Schedule, with the understanding that the work to be done and the materials to be furnished under unit price bids may be increased or decreased not exceeding twenty-five percent (25%) of the total money value of the contract without in any way invalidating the bid prices.

Examination of Specifications, Special Provisions and Site of Work. All Bidders are required to examine carefully the site of the proposed work, the Bid Form, Plans, Standard Specifications, Supplemental Specifications, Special Provisions, Agreement Form and Bond Forms. The submission of a Bid Form shall be prima facie evidence that the Bidder has made such examination and has judged for and satisfied himself as to the conditions to be encountered; as to the character quality and quantities of work to be performed and materials to be furnished; as to the requirements of Plans, Specifications, Supplemental Specifications, Special Provisions, Agreement and Bonds; and as to the contingencies. No adjustments or compensation will be allowed for losses caused by failure to comply with the above requirements.

Familiarity with Laws and Ordinances. All applicable laws, ordinances, and the rules and regulations of all authorities having jurisdiction over construction of the Project shall apply to the contract throughout. Bidders shall familiarize themselves with all such applicable laws, ordinances and regulations, and comply with their requirements which may directly or indirectly affect the work or its prosecution, and any materials or equipment used in the work. No adjustments or compensation will be allowed for losses caused by failure to comply with the above requirements.

Details. The Bidder must specify for both dollars and cents (without interlineation, alterations or erasures, unless initialed by the signer of the proposal) a unit price for each of the separate items for which a quantity is given in the proposal form (except when alternate bids are called for on items) and shall show the products of the respective unit prices and the estimated quantities in the columns provided for that purpose except that any item noted for a "Lump Sum" bid shall have the same amount under the column provided in the proposal for "Unit Price" as that written numerically in the "Amount Bid" column. All figures shall be inked or typed. The Owner will check the extension of each item given in the proposal and correct all errors or discrepancies. The gross sum obtained by adding all of the products of the unit prices and the various estimated quantities

listed in the proposal with the lump sum items shall prevail and this shall be the contract bid price.

Signing. The Bidder's proposal must be signed in ink by the individual, by one or more members of the partnership, or by one or more offices of a corporation, or by an agent of the Contractor legally qualified and acceptable to the Owner. If the proposal is made by an individual, his name and post office address must be shown; by a corporation, the name of the corporation and the business address of its corporate officials must be shown. The proposal Bid Bond shall be properly signed by the Bidder and the surety.

Irregular Proposal. Proposals will be considered irregular and may be rejected if they contain any omissions, alterations of form, additions not called for, alternate bids unless called for, incomplete bids, erasures or alterations not initialed by the person signing the proposal, or other irregularities of any kind.

Information. The Owner shall provide to Bidders prior to Bidding all information which is pertinent to, and delineates and describes, the land owned, and rights-of-way acquired or to be acquired.

Contract Documents. The Contract Documents contain the provisions required for the construction of the Project. Information obtained from an officer, agent, or employee of the Owner or any other person shall not affect the risks or obligations assumed by the Contractor or relieve him from fulfilling any of the conditions of the contract.

Bond Requirements. Each Bid must be accompanied by a Bid Bond payable to the Owner for five percent of the total amount of the Bid not to exceed \$10,000.00. As soon as the Bid prices have been compared, the Owner will return the Bonds of all except the three lowest responsible Bidders. When the Agreement is executed, the Bonds of the two remaining unsuccessful Bidders will be returned. The Bid Bond of the successful Bidder will be retained until the Payment Bond and Performance Bond have been executed and approved, after which it will be returned. A certified check may be used in lieu of a Bid Bond.

A Performance Bond in the amount of 100 percent of the Contract price, with a corporate surety approved by the Owner, will be required for the faithful performance of the contract.

A Payment Bond in the amount of 50 percent of the Contract price, with a corporate surety approved by the Owner, will be required to guarantee the payment by the Contractor of all costs of labor, materials, equipment, subcontractors, etc. necessary to complete the work in accordance with the Contract.

Attorneys-in-fact who sign Bid Bonds or Payment Bonds and Performance Bonds must file with each Bond a certified and effective dated copy of their power of attorney.

Execution of Agreement. The party to whom the contract is awarded will be required to execute the Agreement and obtain the Performance Bond and Payment Bond within fifteen (15) calendar days from the date when Notice of Award is delivered to the Bidder. The Notice of Award shall be accompanied by the necessary Agreement and Bond forms. In case of failure of the Bidder to execute the Agreement, the Owner may at his option consider the Bidder in default, in which case the Bid Bond accompanying the proposal shall become the property of the Owner to be processed

in accordance with prevailing law.

The Owner within twenty (20) days of receipt of an acceptable Performance Bond, Payment Bond and Agreement signed by the party to whom the Agreement was awarded shall sign the Agreement and return to such party an executed duplicate of the Agreement. Should the Owner not execute the Agreement within such period, the Bidder may by Written Notice withdraw his signed Agreement. Such notice of withdrawal shall be effective upon receipt of the notice by the Owner.

Notice to Proceed. The Notice to Proceed shall be issued within fifteen (15) days of the execution of the Agreement by the Owner. Should there be reasons why the Notice to Proceed cannot be issued within such period, the time may be extended by mutual agreement between the Owner and the Contractor. If the Notice to Proceed has not been issued within the fifteen (15) day period or within the period mutually agreed upon, the Contractor may terminate the Agreement without further liability on the part of either party.

Qualifications of Bidders. The Owner may make such investigations as he deems necessary to determine the ability of the Bidder to perform the work, and the Bidder shall furnish to the Owner all such information and data for this purpose as the Owner may request. The Owner reserves the right to reject any Bid if the evidence submitted by, or investigation of, such Bidder fails to satisfy the Owner that such Bidder is properly qualified to carry out the obligations of the Agreement and to complete the Work contemplated therein.

Responsibilities of Bidders. Each Bidder is responsible for inspecting the site and for reading and being thoroughly familiar with the Contract Documents. The failure or omission of any

Bidder to do any of the foregoing shall in no way relieve any Bidder from any obligation in respect to this Bid.

The low Bidder shall supply the names and addresses of major material Suppliers, and Subcontractors when requested to do so by the Owner.

Engineer. The Engineer is Southern Engineering Solutions, Inc., P. O. Box 610 (201 East Troy Street), Andalusia, Alabama 36420.



**BID BOND**

KNOW ALL MEN BY THESE PRESENTS, that we, the undersigned, \_\_\_\_\_  
\_\_\_\_\_ as Principal, and  
\_\_\_\_\_ as Surety, are hereby held and firmly bound unto the **City of  
Jackson** as OWNER in the penal sum of  
\_\_\_\_\_ for the payment of which, well and  
truly to be made, we hereby jointly and severally bind ourselves, successors and assigns. Signed,  
this \_\_\_\_\_ day of \_\_\_\_\_, 2024.

The Condition of the above obligation is such that whereas the Principal has submitted to  
the **City of Jackson** a certain BID, attached hereto and hereby made a part hereof to enter into a  
contract in writing, for the

**FY 2023 RAA STREET RESURFACING AND REPAIRS**

NOW THEREFORE,

- (a) If said BID shall be rejected, or
- (b) If said BID shall be accepted and the Principal shall execute and deliver a contract in  
the Form of Contract attached hereto (properly completed in accordance with said  
BID) and shall furnish a BOND for his faithful performance of said contract, and for  
the payment of all persons performing labor or furnishing materials in connection  
herewith, and shall in all other respects perform the agreement created by the  
acceptance of said BID,

then this obligation shall be void, otherwise the same shall remain in force and effect; it being  
expressly understood and agreed that the liability of the Surety for any and all claims hereunder  
shall, in no event, exceed the penal amount of this obligation as herein stated.

The Surety, for value received, hereby stipulates and agrees that the obligations of said Surety and its BOND shall be in no way impaired or affected by any extension of the time within which the OWNER may accept such BID; and said Surety does hereby waive notice of any such extension.

IN WITNESS WHEREOF, the Principal and the Surety have hereunto set their hands and seals, and such of them as are corporations have caused their corporate seals to be hereto affixed and these presents to be signed by their proper officers, the day and year first set forth above.

\_\_\_\_\_(L.S.)  
Principal

\_\_\_\_\_  
Surety

By: \_\_\_\_\_

IMPORTANT -- Surety companies executing BONDS must appear on the Treasury Department's most current list (Circular 570 as amended) and be authorized to transact business in the state where the project is located.

**Proposal for the Construction of**  
**FY 2023 RAA STREET RESURFACING AND REPAIRS**  
**For**  
**CITY OF JACKSON**

Date: \_\_\_\_\_

Proposal of \_\_\_\_\_  
(Legal Name of Bidder)

Of \_\_\_\_\_  
(Mailing Address of Bidder)

License No \_\_\_\_\_, for the construction of **FY 2023 RAA STREET RESURFACING AND REPAIRS**

To the **CITY OF JACKSON**, hereinafter referred to as the Owner:

The following proposal is made in behalf of the undersigned Bidder and no others. Evidence of authority to submit the proposal is herewith furnished. The proposal is made without collusion on the part of any other person, firm or corporation.

The undersigned Bidder certifies that he has carefully examined the Plans for this project and Specifications attached, including the Special Provisions, and has personally examined the site of the work. On the basis of the Specifications and Plans, the undersigned Bidder proposes to furnish all necessary machinery, tools, apparatus, and other means of construction, and do all the work and furnish all the material in the manner specified.

The undersigned Bidder agrees to commence work under this contract on or before a date to be specified in a written Notice to Proceed issued by the Owner and to fully complete the project within **SIXTY (60)** calendar days thereafter.

The undersigned Bidder understands that the quantities below are approximate only and are subject to either increase or decrease and hereby proposes to perform any increase or decrease in quantities of work at the unit price bid.

The undersigned Bidder agrees to perform all "Force Account or Extra Work" that may be required of him on the basis provided in the specifications attached, and to give such work his personal attention in order to see that it is economically performed.

The undersigned Bidder also proposes to furnish a Performance Bond, in an amount equal to the total amount of his bid. This bond shall serve not only to guarantee the completion of the work on the part of the undersigned Bidder, but also to guarantee the excellence of both workmanship and materials until the work is finally accepted.

The undersigned Bidder encloses a Certified Check or Bid Bond in the amount of 5% of amount bid, not to exceed \$10,000.00 and hereby agrees that in case of his failure to execute a contract and furnish the required bond within 5 days after Notice of Award, the amount of the check or Bid bond will be forfeited to the owner as liquidated damages arising out of his failure to execute a contract as proposed. It is understood that in case the work is not awarded to the undersigned Bidder, the check or Bid bond will be returned as provided in the Specifications hereto attached.

The undersigned Bidder agrees to pay to the Owner as liquidated damages the amount of **\$500.00** per calendar day for any overrun in contract time for which a time extension is not granted by the Owner, as provided in Section 5 of the Supplemental General Conditions.

The undersigned Bidder acknowledges receipt of the following Addenda:

No. \_\_\_\_\_, Dated \_\_\_\_\_.

No. \_\_\_\_\_, Dated \_\_\_\_\_.

No. \_\_\_\_\_, Dated \_\_\_\_\_.

No. \_\_\_\_\_, Dated \_\_\_\_\_.

The Bidder agrees that this bid shall be good and may not be withdrawn for a period of 30 calendar days after the scheduled closing time for receiving bids, except as approved by the Owner.

The Bidder understands that the Owner reserves the right to reject any or all bids and to waive any informalities in the bidding.

The following unit prices shall include all labor, materials, overhead, profit, insurance, etc., to cover the finished work of the several kinds called for.

The undersigned Bidder agrees to perform all the work described in the Contract Documents for the following unit prices:

Left Blank intentionally...must order  
plans to Bid and receive this page

Signature of Bidder (if a firm or individual) \_\_\_\_\_

By \_\_\_\_\_

Address of Bidder \_\_\_\_\_

Names and addresses of members of firm \_\_\_\_\_

\_\_\_\_\_

\_\_\_\_\_

\_\_\_\_\_

Signature of Bidder (if a corporation) \_\_\_\_\_

\_\_\_\_\_  
President Address

\_\_\_\_\_  
Secretary Address

\_\_\_\_\_  
Treasurer Address

Corporate Seal

Name of state under the law of  
which the corporation is chartered:

Attest: \_\_\_\_\_  
Secretary

\_\_\_\_\_

**AGREEMENT**

THIS AGREEMENT, made this \_\_\_\_ day of \_\_\_\_\_, 2024, by and between the **City of Jackson**, hereinafter called "OWNER" and \_\_\_\_\_ doing business as a corporation hereinafter called "CONTRACTOR".

WITNESSETH: That for and in consideration of the payments and agreements hereinafter mentioned:

1. The CONTRACTOR will commence and complete the construction of

**FY 2023 RAA STREET RESURFACING AND REPAIRS**

2. The CONTRACTOR will furnish all of the material, supplies, tools, equipment, labor and other services necessary for the construction and completion of the PROJECT described herein.

3. The CONTRACTOR will commence the work required by the CONTRACT DOCUMENTS within **10** calendar days after the date of the NOTICE TO PROCEED and will complete the same within **sixty (60)** calendar days unless the period for completion is extended otherwise by the CONTRACT DOCUMENTS.

4. The CONTRACTOR agrees to perform all of the WORK described in the CONTRACT DOCUMENTS and comply with the terms therein for the sum of \_\_\_\_\_, or as shown in the BID schedule.

5. The term "CONTRACT DOCUMENTS" means and includes the following:

- (A) ADVERTISEMENT FOR BIDS
- (B) INFORMATION FOR BIDDERS
- (C) BID

- (D) BID BOND
- (E) AGREEMENT
- (F) GENERAL CONDITIONS
- (G) SUPPLEMENTAL GENERAL CONDITIONS
- (H) PAYMENT BOND
- (I) PERFORMANCE BOND
- (J) NOTICE OF AWARD
- (K) NOTICE TO PROCEED
- (L) CHANGE ORDER
- (M) DRAWINGS prepared by **Southern Engineering Solutions, Inc.** dated **January 2024**
- (N) SPECIFICATIONS prepared or issued by **Southern Engineering Solutions, Inc.,** dated **January 2024**
- (O) ADDENDA
  - No.\_\_\_\_\_, dated \_\_\_\_\_, 20\_\_
  - No.\_\_\_\_\_, dated \_\_\_\_\_, 20\_\_
  - No.\_\_\_\_\_, dated \_\_\_\_\_, 20\_\_
  - No.\_\_\_\_\_, dated \_\_\_\_\_, 20\_\_

6. The OWNER will pay to the CONTRACTOR in the manner and at such times as set forth in the General Conditions such amounts as required by the CONTRACT DOCUMENTS.

7. This AGREEMENT shall be binding upon all parties hereto and their respective heirs, executors, administrators, successors, and assigns.



IN WITNESS WHEREOF, the parties hereto have executed, or caused to be executed by their duly authorized officials, this Agreement in three (3) each of which shall be deemed an original on the date first above written.

OWNER:  
\_\_\_\_\_ City of Jackson \_\_\_\_\_

BY: \_\_\_\_\_

Name: Paul South  
(Please Type)

Title: Mayor

(SEAL)

ATTEST:

\_\_\_\_\_

Name: Reta Corley  
(Please Type)

Title: City Clerk

CONTRACTOR:  
\_\_\_\_\_

BY: \_\_\_\_\_

Name: \_\_\_\_\_  
(Please Type)

(SEAL)

Address: \_\_\_\_\_

\_\_\_\_\_

ATTEST:

\_\_\_\_\_

Name: \_\_\_\_\_  
(Please Type)

**PAYMENT BOND**

KNOW ALL MEN BY THESE PRESENTS: that

\_\_\_\_\_

(Name of Contractor)

\_\_\_\_\_

a \_\_\_\_\_, herein called Principal, and

\_\_\_\_\_

(Name of Surety)

\_\_\_\_\_

(Address of Surety)

hereinafter called Surety, are held and firmly bound unto

**City of Jackson  
400 Commerce Street; Jackson, Alabama 36420**

hereinafter called OWNER, in the penal sum of \_\_\_\_\_ Dollars, \$(\_\_\_\_\_) in lawful money of the United States, for the payment of which sum well and truly to be made, we bind ourselves, successors, and assigns, jointly and severally, firmly by these presents.

THE CONDITION OF THIS OBLIGATION is such that whereas, the Principal entered into a certain contract with the OWNER, dated the \_\_\_\_\_ day of \_\_\_\_\_, 2024, a copy of which is hereto attached and made a part hereof for the construction of:

**FY 2023 RAA STREET RESURFACING AND REPAIRS**

NOW, THEREFORE, if the Principal shall promptly make payment to all persons, firms, SUBCONTRACTORS, and corporations furnishing materials for or performing labor in the prosecution of the WORK provided for in such contract, and any authorized extension or modification thereof, including all amounts due for materials, lubricants, oil, gasoline, coal and coke, repairs on machinery, equipment and tools, consumed or used in connection with the construction of such WORK, and all insurance premiums on said WORK, and for all labor, performed in such WORK whether by SUBCONTRACTOR or otherwise, then this obligation shall be void; otherwise to remain in full force and effect.

PROVIDED, FURTHER, that the said Surety for value received hereby stipulates and agrees that no change, extension of time, alteration or addition to the terms of the contract or to the WORK to be performed thereunder or the SPECIFICATIONS accompanying the same shall in any wise affect its obligation on this BOND, and it does hereby waive notice of any such change, extension of time, alteration or addition to the terms of the contract or to the WORK or to the SPECIFICATIONS.

PROVIDED, FURTHER, that no final settlement between the OWNER and the CONTRACTOR shall abridge the right of any beneficiary hereunder, whose claim may be unsatisfied.

IN WITNESS WHEREOF, this instrument is executed in **five (5)** counterparts, each one of which shall be deemed an original, this the \_\_\_\_\_ day of \_\_\_\_\_, 2024.

ATTEST:

\_\_\_\_\_  
(Principal) Secretary

\_\_\_\_\_  
Principal

(SEAL)

By \_\_\_\_\_ (s)

\_\_\_\_\_  
Witness as to Principal

\_\_\_\_\_  
(Address)

\_\_\_\_\_  
(Address)

ATTEST:

\_\_\_\_\_  
(Surety) Secretary

\_\_\_\_\_  
Surety

(SEAL)

By \_\_\_\_\_

\_\_\_\_\_  
Witness as to Surety

\_\_\_\_\_  
Attorney-in-Fact

\_\_\_\_\_  
(Address)

\_\_\_\_\_  
(Address)

NOTE: Date of BOND must not be prior to date of Contract.  
If CONTRACTOR is Partnership, all partners should execute BOND.

IMPORTANT: Surety companies executing BONDS must appear on the Treasury Department's most current list (Circular 570 as amended) and be authorized to transact business in the State where the PROJECT is located.

**PERFORMANCE BOND**

KNOW ALL MEN BY THESE PRESENTS: that

\_\_\_\_\_

(Name of Contractor)

\_\_\_\_\_

a \_\_\_\_\_, hereinafter called Principal, and  
(Corporation, Partnership, or Individual)

\_\_\_\_\_

(Name of Surety)

\_\_\_\_\_

(Address of Surety)

hereinafter called Surety, are held and firmly bound unto

**City of Jackson  
400 Commerce Street; Jackson, Alabama 36420**

hereinafter called OWNER, in the penal sum of \_\_\_\_\_ Dollars, \$(\_\_\_\_) in lawful money of the United States, for the payment of which sum well and truly to be made, we bind ourselves, successors, and assigns, jointly and severally, firmly by these presents.

THE CONDITION OF THIS OBLIGATION is such that whereas, the Principal entered into a certain contract with the OWNER, dated the \_\_\_\_\_ day of \_\_\_\_\_, 2023, a copy of which is hereto attached and made a part hereof for the construction of:

**FY 2023 RAA STREET RESURFACING AND REPAIRS**

NOW, THEREFORE, if the Principal shall well, truly and faithfully perform its duties, all the undertakings, covenants, terms, conditions, and agreements of said contract during the original term thereof, and any extensions thereof which may be granted by the OWNER, with or without notice to the Surety and during the one year guaranty period, and if he shall satisfy all claims and demands incurred under such contract, and shall fully indemnify and save harmless the OWNER from all costs and damages which it may suffer by reason of failure to do so, and shall reimburse and repay the OWNER all outlay and expense which the OWNER may incur in making good any default, then this obligation shall be void; otherwise to remain in full force and effect.

PROVIDED, FURTHER, that the said surety, for value received hereby stipulates and agrees that no change, extension of time, alteration or addition to the terms of the contract or to WORK to be performed thereunder or the SPECIFICATIONS accompanying the same shall in any wise affect its obligation on this BOND, and it does hereby waive notice of any such change, extension of time, alteration or addition to the terms of the contract or to the WORK or to the SPECIFICATIONS.

PROVIDED, FURTHER, that no final settlement between the OWNER and the CONTRACTOR shall abridge the right of any beneficiary hereunder, whose claim may be unsatisfied.

IN WITNESS WHEREOF, this instrument is executed in **five (5)** counterparts, each on of which shall be deemed an original, this the \_\_\_\_\_ day of \_\_\_\_\_, 2024.

ATTEST:

\_\_\_\_\_  
(Principal) Secretary

\_\_\_\_\_  
Principal

(SEAL)

By \_\_\_\_\_ (s)

\_\_\_\_\_  
Witness as to Principal

\_\_\_\_\_  
(Address)

\_\_\_\_\_  
(Address)

ATTEST:

\_\_\_\_\_  
(Surety) Secretary

\_\_\_\_\_  
Surety

(SEAL)

By \_\_\_\_\_  
Attorney-in-Fact

\_\_\_\_\_  
Witness as to Surety

\_\_\_\_\_  
(Address)

\_\_\_\_\_  
(Address)

NOTE: Date of BOND must not be prior to date of Contract.

If CONTRACTOR is Partnership, all partners should execute BOND.

IMPORTANT: Surety companies executing BONDS must appear on the Treasury Department's most current list (Circular 570 as amended) and be authorized to transact business in the state where the PROJECT is located.

**NOTICE OF AWARD**

To:

PROJECT Description: **FY 2023 RAA STREET RESURFACING AND REPAIRS**

The OWNER has considered the BID submitted by you for the above described WORK in response to its Advertisement for Bids dated \_\_\_\_\_, 2024, and Information for Bidders.

You are hereby notified that your BID has been accepted for items in the amount of \$\_\_\_\_\_.

You are required by the Information for Bidders to execute the Agreement and furnish the required CONTRACTOR'S Performance BOND, Payment BOND and certificates of insurance within five (5) calendar days from the date of this Notice to you.

If you fail to execute said Agreement and to furnish said BONDS within five (5) days from the date of this Notice, said OWNER will be entitled to consider all your rights arising out of the OWNER'S acceptance of your BID as abandoned and as a forfeiture of your BID BOND. The OWNER will be entitled to such other rights as may be granted by law.

You are required to return an acknowledged copy of this NOTICE OF AWARD to the OWNER.

Dated this \_\_\_\_ day of \_\_\_\_\_, 2024.

\_\_\_\_\_  
City of Jackson  
Owner

By \_\_\_\_\_  
Paul South

Title \_\_\_\_\_  
Mayor

**ACCEPTANCE OF NOTICE**

Receipt of the above NOTICE OF AWARD is hereby acknowledged

by \_\_\_\_\_,

this the \_\_\_\_\_ day \_\_\_\_\_, 2024

By \_\_\_\_\_

Title \_\_\_\_\_

**NOTICE TO PROCEED**

To: \_\_\_\_\_ Date: \_\_\_\_\_

PROJECT Description: **FY 2023 RAA STREET RESURFACING AND REPAIRS**

You are hereby notified to commence WORK in accordance with the Agreement dated \_\_\_\_\_, 2024, on or before \_\_\_\_\_, 2024, and you are to complete the WORK within **sixty (60)** consecutive calendar days thereafter.

The date of completion of all WORK is therefore \_\_\_\_\_, 2024.

\_\_\_\_\_  
City of Jackson  
Owner

By \_\_\_\_\_  
Paul South

Title Mayor

ACCEPTANCE OF NOTICE

Receipt of the above NOTICE OF AWARD is hereby acknowledged

by \_\_\_\_\_,

this the \_\_\_\_\_ day \_\_\_\_\_, 2024

By \_\_\_\_\_

Title \_\_\_\_\_

**CHANGE ORDER**

Order No.

Date:

Agreement Date:

NAME OF PROJECT:

OWNER:

CONTRACTOR:

The following changes are hereby made to the CONTRACT DOCUMENTS:

Justification:

Change to CONTRACT PRICE:

Original CONTRACT PRICE:                 \$

Current CONTRACT PRICE adjusted by previous CHANGE ORDER \$

The CONTRACT PRICE including this CHANGE ORDER will be (increased) (decreased) by:  
\$

The new CONTRACT PRICE including this CHANGE ORDER will be \$

Change to CONTRACT TIME:

The CONTRACT TIME will be (increased) (decreased) by \_\_\_\_\_ calendar days.

The date for completion of all work will be \_\_\_\_\_(Date).

Approvals Required:

To be effective this Order must be approved by the Federal agency if it changes the scope or objective of the PROJECT, or as may otherwise be required by the SUPPLEMENTAL GENERAL CONDITIONS.

Requested by:

Recommended by:

Ordered by:

Accepted by:  
Federal Agency Approval (where applicable)



**CERTIFICATION BY OWNER**

I, the undersigned, Paul South, the duly authorized and acting official representative of the City of Jackson do hereby certify as follows:

This contract is let in compliance with the provisions of Title 39, Code of Alabama (1975, as amended), and all other applicable provisions of law.

Signature \_\_\_\_\_

Title Mayor

Date \_\_\_\_\_

## GENERAL CONDITIONS

- |  |   |
|--|---|
| 1. Definitions                                 | 17. Subsurface Conditions                     |
| 2. Additional Instructions and Detail Drawings | 18. Suspension of Work, Termination and Delay |
| 3. Schedules, Reports and Records              | 19. Payments to Contractor                    |
| 4. Drawings and Specifications                 | 20. Acceptance of Final Payment as Release    |
| 5. Shop Drawings                               | 21. Insurance                                 |
| 6. Materials, Services and Facilities          | 22. Contract Security                         |
| 7. Inspection and Testing                      | 23. Assignments                               |
| 8. Substitutions                               | 24. Indemnification                           |
| 9. Patents                                     | 25. Separate Contracts                        |
| 10. Surveys, Permits, Regulations              | 26. Subcontracting                            |
| 11. Protection of Work, Property, Persons      | 27. Engineer's Authority                      |
| 12. Supervision by Contractor                  | 28. Land and Rights of Way                    |
| 13. Changes in the Work                        | 29. Guaranty                                  |
| 14. Changes in the Contract Price              | 30. Governing Law and Dispute Resolution      |
| 15. Time for Completion and Liquidated Damages | 31. Taxes                                     |
| 16. Correction of Work                         |   |

### 1. DEFINITIONS

- 1.1 Wherever used in the CONTRACT DOCUMENTS, the following terms shall have the meanings indicated which shall be applicable to both the singular and plural thereof:
- 1.2 ADDENDA -- Written or graphic instruments issued prior to the execution of the Agreement which modify or interpret the CONTRACT DOCUMENTS, DRAWINGS and SPECIFICATIONS, by additions, deletions, clarifications or corrections.
- 1.3 BID -- The offer or proposal of the BIDDER submitted on the prescribed form setting forth the prices for the WORK to be performed.
- 1.4 BIDDER -- Any person, firm or corporation submitting a BID for the WORK.
- 1.5 BONDS -- Bid, Performance, and Payment Bonds and other instruments of security, furnished by the CONTRACTOR and his surety in accordance with the CONTRACT DOCUMENTS.
- 1.6 CHANGE ORDER -- A written order to the CONTRACTOR authorizing an addition, deletion or revision in the WORK within the general scope of the CONTRACT DOCUMENTS, or authorizing an adjustment in the CONTRACT PRICE or CONTRACT TIME.
- 1.7 CONTRACT DOCUMENTS -- The contract, including Advertisement For Bids, Information for Bidders, BID, Bid Bond, Agreement, Payment Bond, Performance Bond, NOTICE OF AWARD, NOTICE TO PROCEED, CHANGE ORDER, DRAWINGS, SPECIFICATIONS, and ADDENDA.
- 1.8 CONTRACT PRICE -- The total monies payable to the CONTRACTOR under the terms and conditions of the CONTRACT DOCUMENTS.
- 1.9 CONTRACT TIME -- The number of calendar days stated in the CONTRACT DOCUMENTS for the completion of the WORK.
- 1.10 CONTRACTOR -- The person, firm or corporation with whom the OWNER has executed the Agreement.
- 1.11 DRAWINGS -- The part of the CONTRACT DOCUMENTS which show the characteristics and scope of the WORK to be performed and which have been prepared or approved by the ENGINEER.

- 1.12 ENGINEER -- The person, firm or corporation named as such in the CONTRACT DOCUMENTS.
- 1.13 FIELD ORDER -- A written order effecting a change in the WORK not involving an adjustment in the CONTRACT PRICE or an extension of the CONTRACT TIME, issued by the ENGINEER to the CONTRACTOR during construction.
- 1.14 NOTICE OF AWARD -- The written notice of the acceptance of the BID from the OWNER to the successful BIDDER.
- 1.15 NOTICE TO PROCEED -- Written communication issued by the OWNER to the CONTRACTOR authorizing him to proceed with the WORK and establishing the date of commencement of the WORK.
- 1.16 OWNER -- A public or quasi-public body or authority, corporation, association, partnership, or individual for whom the WORK is to be performed.
- 1.17 PROJECT -- The undertaking to be performed as provided in the CONTRACT DOCUMENTS.
- 1.18 RESIDENT PROJECT REPRESENTATIVE -- The authorized representative of the OWNER who is assigned to the PROJECT site or any part thereof.
- 1.19 SHOP DRAWINGS -- All drawings, diagrams, illustrations, brochures, schedules and other data which are prepared by the CONTRACTOR, a SUBCONTRACTOR, manufacturer, SUPPLIER or distributor, which illustrate how specific portions of the WORK shall be fabricated or installed.
- 1.20 SPECIFICATIONS -- A part of the CONTRACT DOCUMENTS consisting of written descriptions of a technical nature of materials, equipment, construction systems, standards and workmanship.
- 1.21 SUBCONTRACTOR -- An individual, firm or corporation having a direct contract with the CONTRACTOR or with any other SUBCONTRACTOR for the performance of a part of the work at the site.
- 1.22 SUBSTANTIAL COMPLETION -- That date as certified by the ENGINEER when the construction of the PROJECT or a specified part thereof is sufficiently completed, in accordance with the CONTRACT DOCUMENTS, so that the PROJECT or specified part can be utilized for the purposes for which it is intended.
- 1.23 SUPPLEMENTAL GENERAL CONDITIONS -- Modifications to General Conditions required by a Federal agency for participation in the PROJECT and approved by the agency in writing prior to inclusion in the CONTRACT DOCUMENTS, or such requirements that may be imposed by applicable state laws.
- 1.24 SUPPLIER -- Any person or organization who supplies materials or equipment for the WORK, including that fabricated to a special design, but who does not perform labor at the site.
- 1.25 WORK -- All labor necessary to produce the construction required by the CONTRACT DOCUMENTS, and all materials and equipment incorporated or to be incorporated in the PROJECT.
- 1.26 WRITTEN NOTICE--Any notice to any party of the Agreement relative to any part of this Agreement in writing and considered delivered and the service thereof completed, when posted by certified or registered mail to the said party at his last given address, or delivered in person to said party or his authorized representative on the WORK.

## **2. ADDITIONAL INSTRUCTIONS AND DETAIL DRAWINGS**

- 2.1 The CONTRACTOR may be furnished additional instructions and detail drawings, by the ENGINEER, as necessary to carry out the WORK required by the CONTRACT DOCUMENTS.
- 2.2 The additional drawings and instruction thus supplied will become a part of the CONTRACT DOCUMENTS. The CONTRACTOR shall carry out the WORK in accordance with the additional detail drawings and instructions.

### **3. SCHEDULES, REPORTS AND RECORDS**

- 3.1 The CONTRACTOR shall submit to the OWNER such schedule of quantities and costs, progress schedules, payrolls, reports, estimates, records and other data where applicable as are required by the CONTRACT DOCUMENTS for the WORK to be performed.
- 3.2 Prior to the first partial payment estimate the CONTRACTOR shall submit construction progress schedules showing the order in which he proposes to carry on the WORK, including dates at which he will start the various parts of the WORK, estimated date of completion of each part and, as applicable:
  - 3.2.1 The dates at which special detail drawings will be required; and
  - 3.2.2 Respective dates for submission of SHOP DRAWINGS, the beginning of manufacture, the testing and the installation of materials, supplies and equipment.
- 3.3 The CONTRACTOR shall also submit a schedule of payments that he anticipates he will earn during the course of the WORK.

### **4. DRAWINGS AND SPECIFICATIONS**

- 4.1 The intent of the DRAWINGS and SPECIFICATIONS is that the CONTRACTOR shall furnish all labor, materials, tools, equipment, and transportation necessary for the proper execution of the WORK in accordance with the CONTRACT DOCUMENTS and all incidental work necessary to complete the PROJECT in an acceptable manner, ready for use, occupancy or operation by the OWNER.
- 4.2 In case of conflict between the DRAWINGS and SPECIFICATIONS, the SPECIFICATIONS shall govern. Figure dimensions on DRAWINGS shall govern over scale dimensions, and detailed DRAWINGS shall govern over general DRAWINGS.
- 4.3 Any discrepancies found between the DRAWINGS and SPECIFICATIONS and site conditions or any inconsistencies or ambiguities in the DRAWINGS or SPECIFICATIONS shall be immediately reported to the ENGINEER, in writing, who shall promptly correct such inconsistencies or ambiguities in writing. WORK done by the CONTRACTOR after his discovery of such discrepancies, inconsistencies or ambiguities shall be done at the CONTRACTOR'S risk.

### **5. SHOP DRAWINGS**

- 5.1 The CONTRACTOR shall provide SHOP DRAWINGS as may be necessary for the prosecution of the WORK as required by the CONTRACT DOCUMENTS. The ENGINEER shall promptly review all SHOP DRAWINGS. The ENGINEER'S approval of any SHOP DRAWING shall not release the CONTRACTOR from responsibility for deviations from the CONTRACT DOCUMENTS. The approval of any SHOP DRAWING which substantially deviates from the requirement of the CONTRACT DOCUMENTS shall be evidenced by a CHANGE ORDER.
- 5.2 When submitted for the ENGINEER'S review, SHOP DRAWINGS shall bear the CONTRACTOR'S certification that he has reviewed, checked and approved the SHOP DRAWINGS and that they are in conformance with the requirements of the CONTRACT DOCUMENTS.
- 5.3 Portions of the WORK requiring a SHOP DRAWING or sample submission shall not begin until the SHOP DRAWING or submission has been approved by the ENGINEER. A copy of each approved SHOP DRAWING and each approved sample shall be kept in good order by the CONTRACTOR at the site and shall be available to the ENGINEER.

## **6. MATERIALS, SERVICES AND FACILITIES**

- 6.1 It is understood that, except as otherwise specifically stated in the CONTRACT DOCUMENTS, the CONTRACTOR shall provide and pay for all materials, labor, tools, equipment, water, light, power, transportation, supervision, temporary construction of any nature, and all other services and facilities of any nature whatsoever necessary to execute, complete, and deliver the WORK within the specified time.
- 6.2 Materials and equipment shall be so stored as to insure the preservation of their quality and fitness for the WORK. Stored materials and equipment to be incorporated in the WORK shall be located so as to facilitate prompt inspection.
- 6.3 Manufactured articles, materials and equipment shall be applied, installed, connected, erected, used, cleaned and conditioned as directed by the manufacturer.
- 6.4 Materials, supplies and equipment shall be in accordance with samples submitted by the CONTRACTOR and approved by the ENGINEER.
- 6.5 Materials, supplies or equipment to be incorporated into the WORK shall not be purchased by the CONTRACTOR or the SUBCONTRACTOR subject to a chattel mortgage or under a conditional sale contract or other agreement by which an interest is retained by the seller.

## **7. INSPECTION AND TESTING**

- 7.1 All materials and equipment used in the construction of the PROJECT shall be subject to adequate inspection and testing in accordance with generally accepted standards, as required and defined in the CONTRACT DOCUMENTS.
- 7.2 The OWNER shall provide all inspection and testing services not required by the CONTRACT DOCUMENTS.
- 7.3 The CONTRACTOR shall provide at his expense the testing and inspection services required by the CONTRACT DOCUMENTS.
- 7.4 If the CONTRACT DOCUMENTS, laws, ordinances, rules, regulations or orders of any public authority having jurisdiction require any WORK to specifically be inspected, tested, or approved by someone other than the CONTRACTOR, the CONTRACTOR will give the ENGINEER timely notice of readiness. The CONTRACTOR will then furnish the ENGINEER the required certificates of inspection, testing or approval.
- 7.5 Inspections, tests or approvals by the engineer or others shall not relieve the CONTRACTOR from his obligations to perform the WORK in accordance with the requirements of the CONTRACT DOCUMENTS.
- 7.6 The ENGINEER and his representatives will at all times have access to the WORK. In addition, authorized representatives and agents of any participating Federal or state agency shall be permitted to inspect all work, materials, payrolls, records of personnel, invoices of materials, and other relevant data and records. The CONTRACTOR will provide proper facilities for such access and observation of the WORK and also for any inspection, or testing thereof.
- 7.7 If any WORK is covered contrary to the written instructions of the ENGINEER it must, if requested by the ENGINEER, be uncovered for his observation and replaced at the CONTRACTOR'S expense.
- 7.8 If the ENGINEER considers it necessary or advisable that covered WORK be inspected or tested by others, the CONTRACTOR, at the ENGINEER'S request, will uncover, expose or otherwise make available for observation, inspection or testing as the ENGINEER may require, that portion of the WORK in question, furnishing all necessary labor, materials, tools, and equipment. If it is found that such WORK is defective, the CONTRACTOR will bear all the expenses of such uncovering, exposure, observation, inspection and testing and of satisfactory reconstruction. If, however, such WORK is not found to be defective, the CONTRACTOR will be allowed an increase in the CONTRACT PRICE or an extension of the CONTRACT TIME, or both, directly attributable to such

uncovering, exposure, observation, inspection, testing and reconstruction and an appropriate CHANGE ORDER shall be issued.

## **8. SUBSTITUTIONS**

- 8.1 Whenever a material, article or piece of equipment is identified on the DRAWINGS or SPECIFICATIONS by reference to brand name or catalogue number, it shall be understood that this is referenced for the purpose of defining the performance or other salient requirements and that other products of equal capacities, quality and function shall be considered. The CONTRACTOR may recommend the substitution of a material, article, or piece of equipment of equal substance and function for those referred to in the CONTRACT DOCUMENTS by reference to brand name or catalogue number, and if, in the opinion of the ENGINEER, such material, article, or piece of equipment is of equal substance and function to that specified, the ENGINEER may approve its substitution and use by the CONTRACTOR. Any cost differential shall be deductible from the CONTRACT PRICE and the CONTRACT DOCUMENTS shall be appropriately modified by CHANGE ORDER. The CONTRACTOR warrants that if substitutes are approved, no major changes in the function or general design of the PROJECT will result. Incidental changes or extra component parts required to accommodate the substitute will be made by the CONTRACTOR without a change in the CONTRACT PRICE or CONTRACT TIME.

## **9. PATENTS**

- 9.1 The CONTRACTOR shall pay all applicable royalties and license fees. He shall defend all suits or claims for infringement of any patent rights and save the OWNER harmless from loss on account thereof, except that the OWNER shall be responsible for any such loss when a particular process, design, or the product of a particular manufacturer or manufacturers is specified, however if the CONTRACTOR has reason to believe that the design, process or product specified is an infringement of a patent, he shall be responsible for such loss unless he promptly gives such information to the ENGINEER.

## **10. SURVEYS, PERMITS, REGULATIONS**

- 10.1 The OWNER shall furnish all boundary surveys and establish all base lines for locating the principal component parts of the WORK together with a suitable number of bench marks adjacent to the WORK as shown in the CONTRACT DOCUMENTS. From the information provided by the OWNER, unless otherwise specified in the CONTRACT DOCUMENTS, the CONTRACTOR shall develop and make all detail surveys needed for construction such as slope stakes, batter boards, stakes for pile locations and other working points, lines, elevations and cut sheets.
- 10.2 The CONTRACTOR shall carefully preserve bench marks, reference points and stakes and, in case of willful or careless destruction, he shall be charged with the resulting expense and shall be responsible for any mistakes that may be caused by their unnecessary loss or disturbance.
- 10.3 Permits and licenses of a temporary nature necessary for the prosecution of the WORK shall be secured and paid for by the CONTRACTOR unless otherwise stated in the SUPPLEMENTAL GENERAL CONDITIONS. Permits, licenses and easements for permanent structures or permanent changes in existing facilities shall be secured and paid for by the OWNER, unless otherwise specified. The CONTRACTOR shall give all notices and comply with all laws, ordinances, rules and regulations bearing on the conduct of the WORK as drawn and specified. If the CONTRACTOR observes that the CONTRACT DOCUMENTS are at variance therewith, he shall promptly notify the ENGINEER in writing, and any necessary changes shall be adjusted as provided in Section 13, CHANGES IN THE WORK.

## **11. PROTECTION OF WORK, PROPERTY AND PERSONS**

- 11.1 The CONTRACTOR will be responsible for initiating, maintaining and supervising all safety precautions and programs in connection with the WORK. He will take all necessary precautions for the safety of, and will

provide the necessary protection to prevent damage, injury or loss to all employees on the WORK and other persons who may be affected thereby, all the WORK and all materials or equipment to be incorporated therein, whether in storage on or off the site, and other property at the site or adjacent thereto, including trees, shrubs, lawns, walks, pavements, roadways, structures and utilities not designated for removal, relocation or replacement in the course of construction.

- 11.2 The CONTRACTOR will comply with all applicable laws, ordinances, rules, regulations and orders of any public body having jurisdiction. He will erect and maintain, as required by the conditions and progress of the WORK, all necessary safeguards for safety and protection. He will notify owners of adjacent utilities when prosecution of the WORK may affect them. The CONTRACTOR will remedy all damage, injury or loss to any property caused directly or indirectly, in whole or in part, by the CONTRACTOR, any SUBCONTRACTOR or anyone directly or indirectly employed by any of them or anyone for whose acts any of them be liable, except damage or loss attributable to the fault of the CONTRACT DOCUMENTS or to the acts or omissions of the OWNER or the ENGINEER or anyone employed by either of them or anyone for whose acts either of them may be liable, and not attributable, directly or indirectly, in whole or in part, to the fault or negligence of the CONTRACTOR.
- 11.3 In emergencies affecting the safety of persons or the WORK or property at the site or adjacent thereto, the CONTRACTOR, without special instruction or authorization from the ENGINEER or OWNER, shall act to prevent threatened damage, injury or loss. He will give the ENGINEER prompt WRITTEN NOTICE of any significant changes in the WORK or deviations from the CONTRACT DOCUMENTS caused thereby, and a CHANGE ORDER shall thereupon be issued covering the changes and deviations involved.

## **12. SUPERVISION BY CONTRACTOR**

- 12.1 The CONTRACTOR will supervise and direct the WORK. He will be solely responsible for the means, methods, techniques, sequences and procedures of construction. The CONTRACTOR will employ and maintain on the WORK a qualified supervisor or superintendent who shall have been designated in writing by the CONTRACTOR as the CONTRACTOR'S representative at the site. The supervisor shall have full authority to act on behalf of the CONTRACTOR and all communications given to the supervisor shall be as binding as if given to the CONTRACTOR. The supervisor shall be present on the site at all times as required to perform adequate supervision and coordination of the WORK.

## **13. CHANGES IN THE WORK**

- 13.1 The OWNER may at any time, as the need arises, order changes within the scope of the WORK without invalidating the Agreement. If such changes increase or decrease the amount due under the CONTRACT DOCUMENTS, or in the time required for performance of the WORK, an equitable adjustment shall be authorized by CHANGE ORDER.
- 13.2 The ENGINEER, also, may at any time, by issuing a FIELD ORDER, make changes in the details of the WORK. The CONTRACTOR shall proceed with the performance of any changes in the WORK so ordered by the ENGINEER unless the CONTRACTOR believes that such FIELD ORDER entitles him to a change in CONTRACT PRICE or TIME, or both, in which event he shall give the ENGINEER WRITTEN NOTICE thereof within seven (7) days after the receipt of the ordered change. Thereafter the CONTRACTOR shall document the basis for the change in CONTRACT PRICE or TIME within thirty (30) days. The CONTRACTOR shall not execute such changes pending the receipt of an executed CHANGE ORDER or further instruction from the OWNER.

## **14. CHANGES IN CONTRACT PRICE**

- 14.1 The CONTRACT PRICE may be changed only by a CHANGE ORDER. The value of any WORK covered by a CHANGE ORDER or of any claim for increase or decrease in the CONTRACT PRICE shall be determined by one or more of the following methods in the order of precedence listed below:

- (a) Unit prices previously approved.
- (b) An agreed lump sum.
- (c) The actual cost for labor, direct overhead, materials, supplies, equipment, and other services

necessary

## **15. TIME FOR COMPLETION AND LIQUIDATED DAMAGES**

- 15.1 The date of beginning and the time for completion of the WORK are essential conditions of the CONTRACT DOCUMENTS and the WORK embraced shall be commenced on a date specified in the NOTICE TO PROCEED.
- 15.2 The CONTRACTOR will proceed with the WORK at such rate of progress to insure full completion within the CONTRACT TIME. It is expressly understood and agreed, by and between the CONTRACTOR and the OWNER, that the CONTRACT TIME for the completion of the WORK described herein is a reasonable time, taking into consideration the average climatic and economic conditions and other factors prevailing in the locality of the WORK.
- 15.3 If the CONTRACTOR shall fail to complete the WORK within the CONTRACT TIME, or extension of time granted by the OWNER, then the CONTRACTOR will pay to the OWNER the amount for liquidated damages as specified in the BID for each calendar day that the CONTRACTOR shall be in default after the time stipulated in the CONTRACT DOCUMENTS.
- 15.4 The CONTRACTOR shall not be charged with liquidated damages or any excess cost when the delay in completion of the WORK is due to the following, and the CONTRACTOR has promptly given WRITTEN NOTICE of such delay to the OWNER or ENGINEER.
  - 15.4.1 To any preference, priority or allocation order duly issued by the OWNER.
  - 15.4.2 To unforeseeable causes beyond the control and without the fault or negligence of the CONTRACTOR, including but not restricted to, acts of God, or of the public enemy, acts of the OWNER, acts of another CONTRACTOR in the performance of a contract with the OWNER, fires, floods, epidemics, quarantine restrictions, strikes, freight embargoes, and abnormal and unforeseeable weather: and
  - 15.4.3 To any delays of SUBCONTRACTORS occasioned by any of the causes specified in paragraphs 15.4.1 and 15.4.2 of this article.

## **16. CORRECTION OF WORK**

- 16.1 The CONTRACTOR shall promptly remove from the premises all WORK rejected by the ENGINEER for failure to comply with the CONTRACT DOCUMENTS, whether incorporated in the construction or not, and the CONTRACTOR shall promptly replace and re-execute the WORK in accordance with the CONTRACT DOCUMENTS and without expense to the OWNER and shall bear the expense of making good all WORK of other CONTRACTORS destroyed or damaged by such removal or replacement.
- 16.2 All removal and replacement WORK shall be done at the CONTRACTOR'S expense. If the CONTRACTOR does not take action to remove such rejected WORK within ten (10) days after receipt of WRITTEN NOTICE, the OWNER may remove such WORK and store the materials at the expense of the CONTRACTOR.

## **17. SUBSURFACE CONDITIONS**

- 17.1 The CONTRACTOR shall promptly, and before such conditions are disturbed, except in the event of an emergency, notify the OWNER by WRITTEN NOTICE of:



- 17.1.1 Subsurface or latent physical conditions at the site differing materially from those indicated in the CONTRACT DOCUMENTS: or
  - 17.1.2 Unknown physical conditions at the site, of an unusual nature, differing materially from those ordinarily encountered and generally recognized as inherent in WORK of the character provided for in the CONTRACT DOCUMENTS.
- 17.2 The OWNER shall promptly investigate the conditions, and if he finds that such conditions do so materially differ and cause an increase or decrease in the cost of, or in the time required for, performance of the WORK, an equitable adjustment shall be made and the CONTRACT DOCUMENTS shall be modified by a CHANGE ORDER. Any claim of the CONTRACTOR for adjustment hereunder shall not be allowed unless he has given the required WRITTEN NOTICE; provided that the OWNER may, if he determines the facts so justify, consider and adjust any such claims asserted before the date of final payment.

## **18. SUSPENSION OF WORK, TERMINATION AND DELAY**

- 18.1 The OWNER may suspend the WORK or any portion thereof for a period of not more than ninety days or such further time as agreed upon by the CONTRACTOR by WRITTEN NOTICE to the CONTRACTOR and the ENGINEER which notice shall fix the date on which WORK shall be resumed. The CONTRACTOR will resume that WORK on the date so fixed. The CONTRACTOR will be allowed an increase in the CONTRACT PRICE or an extension of the CONTRACT TIME, or both, directly attributable to any suspension.
- 18.2 If the CONTRACTOR is adjudged as bankrupt or insolvent, or if he makes a general assignment for the benefit of his creditors, or if a trustee or receiver is appointed for the CONTRACTOR or for any of his property, or if he files a petition to take advantage of any debtor's act, or to reorganize under the bankruptcy or applicable laws, or if he repeatedly fails to supply sufficient skilled workmen or suitable materials or equipment, or if he repeatedly fails to make prompt payments to SUBCONTRACTORS or for labor, materials or equipment or if he disregards laws, ordinances, rules, regulations or orders of any public body having jurisdiction of the WORK or if he disregards the authority of the ENGINEER, or if he otherwise violates any provision of the CONTRACT DOCUMENTS, then the OWNER may, without prejudice to any other right or remedy and after giving the CONTRACTOR and his surety a minimum of ten (10) days from delivery of a WRITTEN NOTICE, terminate the services of the CONTRACTOR and take possession of the PROJECT and of all materials, equipment, tools, construction equipment and machinery, thereon owned by the CONTRACTOR, and finish the WORK by whatever method he may deem expedient. In such case the CONTRACTOR shall not be entitled to receive any further payment until the WORK is finished. If the unpaid balance of the CONTRACT PRICE exceeds the direct and indirect costs of completing the PROJECT, including compensation for additional professional services, such excess SHALL BE PAID TO THE CONTRACTOR. If such costs exceed such unpaid balance, the CONTRACTOR will pay the difference to the OWNER. Such costs incurred by the OWNER will be determined by the ENGINEER and incorporated in a CHANGE ORDER.
- 18.3 Where the CONTRACTOR'S services have been so terminated by the OWNER, said termination shall not affect any right of the OWNER against the CONTRACTOR then existing or which may thereafter accrue. Any retention or payment of monies by the OWNER due the CONTRACTOR will not release the CONTRACTOR from compliance with the CONTRACT DOCUMENTS.
- 18.4 After ten (10) days from delivery of a WRITTEN NOTICE to the CONTRACTOR and the ENGINEER, the OWNER may, without cause and without prejudice to any other right or remedy, elect to abandon the PROJECT and terminate the Contract. In such case, the CONTRACTOR shall be paid for all WORK executed and any expense sustained plus reasonable profit.
- 18.5 If, through no act or fault of the CONTRACTOR, the WORK is suspended for a period of more than ninety (90) days by the OWNER or under an order of court or other public authority, or the ENGINEER fails to act on any request for payment within thirty (30) days after it is submitted or the OWNER fails to pay the CONTRACTOR substantially the sum approved by the ENGINEER or awarded by arbitrators within thirty (30) days of its approval and presentation, then the CONTRACTOR may, after ten (10) days from delivery of a WRITTEN NOTICE to the OWNER and the ENGINEER, terminate the CONTRACT and recover from the OWNER payment for all

WORK executed and all expenses sustained. In addition and in lieu of terminating the CONTRACT, if the ENGINEER has failed to act on a request for payment or if the OWNER has failed to make any payment as aforesaid, the CONTRACTOR may upon ten (10) days written notice to the OWNER and the ENGINEER stop the WORK until he has been paid all amounts then due, in which event and upon resumption of the WORK, CHANGE ORDERS shall be issued for adjusting the CONTRACT PRICE or extending the CONTRACT TIME or both to compensate for the costs and delays attributable to the stoppage of the WORK.

- 18.6 If the performance of all or any portion of the WORK is suspended, delayed, or interrupted as a result of a failure of the OWNER or ENGINEER to act within the time specified in the CONTRACT DOCUMENTS, or if no time is specified, within a reasonable time, an adjustment in the CONTRACT PRICE or an extension of the CONTRACT TIME, or both, shall be made by CHANGE ORDER to compensate the CONTRACTOR for the costs and delays necessarily caused by the failure of the OWNER or ENGINEER.

## **19. PAYMENTS TO CONTRACTOR**

- 19.1 At least ten (10) days before each progress payment falls due (but not more often than once a month), the CONTRACTOR will submit to the ENGINEER a partial payment estimate filled out and signed by the CONTRACTOR covering the WORK performed during the period covered by the partial payment estimate and supported by such data as the ENGINEER may reasonably require. If payment is requested on the basis of materials and equipment not incorporated in the WORK but delivered and suitably stored at or near the site, the partial payment estimate shall also be accompanied by such supporting data, satisfactory to the OWNER, as will establish the OWNER's title to the material and equipment and protect his interest therein, including applicable insurance. The ENGINEER will, within ten (10) days after receipt of each partial payment estimate, either indicate in writing his approval of payment and present the partial payment estimate to the OWNER, or return the partial payment estimate to the CONTRACTOR indicating in writing his reasons for refusing to approve payment. In the latter case, the CONTRACTOR may make the necessary corrections and resubmit the partial payment estimate. The OWNER will, within ten (10) days of presentation to him of an approved partial payment estimate, pay the CONTRACTOR a progress payment on the basis of the approved partial payment estimate. The OWNER shall retain ten (10) percent of the amount of each payment until final completion and acceptance of all work covered by the CONTRACT DOCUMENTS. The OWNER at any time, however, after fifty (50) percent of the WORK has been completed, if he finds that satisfactory progress is being made, shall reduce retainage to five (5%) percent on the current and remaining estimates. When the WORK is substantially complete (operational or beneficial occupancy), the retained amount may be further reduced below five (5) percent to only that amount necessary to assure completion. On completion and acceptance of a part of the WORK on which the price is stated separately in the CONTRACT DOCUMENTS, payment may be made in full, including retained percentages, less authorized deductions.
- 19.2 The request for payment may also include an allowance for the cost of such major materials and equipment which are suitably, stored either at or near the site.
- 19.3 Prior to SUBSTANTIAL COMPLETION, the OWNER, with the approval of the ENGINEER and with the concurrence of the CONTRACTOR, may use any completed or substantially completed portions of the WORK. Such use shall not constitute an acceptance of such portions of the WORK.
- 19.4 The OWNER shall have the right to enter the premises for the purpose of doing work not covered by the CONTRACT DOCUMENTS. This provision shall not be construed as relieving the CONTRACTOR of the sole responsibility for the care and protection of the WORK, or the restoration of any damaged WORK except such as may be caused by agents or employees of the OWNER.
- 19.5 Upon completion and acceptance of the WORK, the ENGINEER shall issue a certificate attached to the final payment request that the WORK has been accepted by him under the conditions of the CONTRACT DOCUMENTS. The entire balance found to be due the CONTRACTOR, including the retained percentages, but except such sums as may be lawfully retained by the OWNER, shall be paid to the CONTRACTOR within thirty (30) days of completion and acceptance of the WORK.

19.6 The CONTRACTOR will indemnify and save the OWNER or the OWNER'S agents harmless from all claims growing out of the lawful demands of SUBCONTRACTORS, laborers, workmen, mechanics, materialmen, and furnishers of machinery and parts thereof, equipment, tools, and all supplies, incurred in the furtherance of the performance of the WORK. The CONTRACTOR shall, at the OWNER'S request, furnish satisfactory evidence that all obligations of the nature designated above have been paid, discharged, or waived. If the CONTRACTOR fails to do so the OWNER may, after having notified the CONTRACTOR, either pay unpaid bills or withhold from the CONTRACTOR'S unpaid compensation a sum of money deemed reasonably sufficient to pay any and all such lawful claims until satisfactory evidence is furnished that all liabilities have been fully discharged whereupon payment to the CONTRACTOR shall be resumed, in accordance, with the terms of the CONTRACT DOCUMENTS, but in no event shall the provisions of this sentence be construed to impose any obligations upon the OWNER to either the CONTRACTOR, his Surety, or any third party. In paying any unpaid bills of the CONTRACTOR, any payment so made by the OWNER shall be considered as a payment made under the CONTRACT DOCUMENTS by the OWNER to the CONTRACTOR and the OWNER shall not be liable to the CONTRACTOR for any such payments made in good faith.

19.7 If the OWNER fails to make payment thirty (30) days after approval by the ENGINEER, in addition to other remedies available to the CONTRACTOR, there shall be added to each such payment interest at the maximum legal rate commencing on the first day after said payment is due and continuing until the payment is received by the CONTRACTOR.

## **20. ACCEPTANCE OF FINAL PAYMENT AS RELEASE**

20.1 The acceptance by the CONTRACTOR of final payment shall be and shall operate as a release to the OWNER of all claims and all liability to the CONTRACTOR other than claims in stated amounts as may be specifically excepted by the CONTRACTOR for all things done or furnished in connection with this WORK and for every act and neglect of the OWNER and others relating to or arising out of this WORK. Any payment, however, final or otherwise, shall not release the CONTRACTOR or his sureties from any obligations under the CONTRACT DOCUMENTS or the Performance BOND and Payment BONDS.

## **21. INSURANCE**

21.1 The CONTRACTOR shall purchase and maintain such insurance as will protect him from claims set forth below which may arise out of or result from the CONTRACTOR'S execution of the WORK, whether such execution be by himself or by any SUBCONTRACTOR or by anyone directly or indirectly employed by any of them, or by anyone for whose acts any of them may be liable:

21.1.1 Claims under workmen's compensation disability benefit and other similar employee benefit acts;

21.1.2 Claims for damages because of bodily injury, occupational sickness or disease, or death of his employees;

21.1.3 Claims for damages because of bodily injury, sickness or disease, or death of any person other than his employees;

21.1.4 Claims for damages insured by usual personal injury liability coverage which are sustained (1) by any person as a result of an offense directly or indirectly related to the employment of such person by the CONTRACTOR, or (2) by any other person; and

21.1.5 Claims for damages because of injury to or destruction of tangible property, including loss of use resulting therefrom.

21.2 Certificates of Insurance acceptable to the OWNER shall be filed with the OWNER prior to commencement of the WORK. These Certificates shall contain a provision that coverages afforded under the policies will not be canceled unless at least fifteen (15) days prior WRITTEN NOTICE has been given to the OWNER.

- 21.3 The CONTRACTOR shall procure and maintain, at his own expense, during the CONTRACT TIME, liability insurance as hereinafter specified;
- 21.3.1 CONTRACTOR'S General Public Liability and Property Damage Insurance including vehicle coverage issued to the CONTRACTOR and protecting him from all claims for personal injury, including death, and all claims for destruction of or damage to property, arising out of or in connection with any operations under the CONTRACT DOCUMENTS, whether such operations be by himself or by any SUBCONTRACTOR under him, or anyone directly or indirectly employed by the CONTRACTOR or by a SUBCONTRACTOR under him. Insurance shall be written with a limit of liability of not less than, \$500,000 for all damages arising out of bodily injury, including death, at any time resulting therefrom, sustained by any one person in any one accident; and a limit of liability of not less than \$500,000 aggregate for any such damages sustained by two or more persons in any one accident. Insurance shall be written with a limit of liability of not less than \$200,000 for all property damage sustained by any one person in any one accident; and a limit of liability of not less than \$200,000 aggregate for any such damage sustained by two or more persons in any one accident.
- 21.3.2 The CONTRACTOR shall acquire and maintain, if applicable, Fire and Extended Coverage insurance upon the PROJECT to the full insurable value thereof for the benefit of the OWNER, the CONTRACTOR, and SUBCONTRACTORS as their interest may appear. This provision shall in no way release the CONTRACTOR or CONTRACTOR'S surety from obligations under the CONTRACT DOCUMENTS to fully complete the PROJECT.
- 21.4 The CONTRACTOR shall procure and maintain, at his own expense, during the CONTRACT TIME, in accordance with the provisions of the laws of the state in which the work is performed, Workmen's Compensation Insurance, including occupational disease provisions, for all of his employees at the site of the PROJECT and in case any work is sublet, the CONTRACTOR shall require such SUBCONTRACTOR similarly to provide Workmen's Compensation Insurance, including occupational disease provisions for all of the latter's employees unless such employees are covered by the protection afforded by the CONTRACTOR. In case any class of employees engaged in hazardous work under this contract at the site of the PROJECT is not protected under Workmen's Compensation statute, the CONTRACTOR shall provide, and shall cause each SUBCONTRACTOR to provide, adequate and suitable insurance for the protection of his employees not otherwise protected.
- 21.5 The CONTRACTOR shall secure, if applicable, "All Risk" type Builder's Risk Insurance for WORK to be performed. Unless specifically authorized by the OWNER, the amount of such insurance shall not be less than the CONTRACT PRICE totaled in the BID. The policy shall cover not less than the losses due to fire, explosion, hail, lightning, vandalism, malicious mischief, wind, collapse, riot, aircraft, and smoke during the CONTRACT TIME, and until the WORK is accepted by the OWNER. The policy shall name as the insured the CONTRACTOR, the ENGINEER, and the OWNER.

## **22. CONTRACT SECURITY**

- 22.1 The CONTRACTOR shall within ten (10) days after the receipt of the NOTICE OF AWARD furnish the OWNER with a Performance Bond and a Payment Bond in penal sums equal to the amount of the CONTRACT PRICE, conditioned upon the performance by the CONTRACTOR of all undertakings, covenants, terms, conditions and agreements of the CONTRACT DOCUMENTS. and upon the prompt payment by the CONTRACTOR to all persons supplying labor and materials in the prosecution of the WORK provided by the CONTRACT DOCUMENTS. Such BONDS shall be executed by the CONTRACTOR and a corporate bonding company licensed to transact such business in the state in which the WORK is to be performed and named on the current list of "Surety Companies Acceptable on Federal Bonds" as published in the Treasury Department Circular Number 570. The expense of these BONDS shall be borne by the CONTRACTOR. If at any time a surety on any such BOND is declared a bankrupt or loses its right to do business in the state in which the WORK is to be performed or is removed from the list of Surety Companies accepted on Federal BONDS, CONTRACTOR shall within ten (10) days after notice from the OWNER to do so, substitute an acceptable BOND (or BONDS) in such form and sum and signed by such other surety or sureties as may be satisfactory to

the OWNER. The premiums on such BOND shall be paid by the CONTRACTOR. No further payments shall be deemed due nor shall be made until the new surety or sureties shall have furnished an acceptable BOND to the OWNER.

### **23. ASSIGNMENTS**

- 23.1 Neither the CONTRACTOR nor the OWNER shall sell, transfer, assign or otherwise dispose of the Contract or any portion thereof or of his right, title or interest therein, or his obligations thereunder, without written consent of the other party.

### **24. INDEMNIFICATION**

- 24.1 The CONTRACTOR will indemnify and hold harmless the OWNER and the ENGINEER and their agents and employees from and against all claims, damages, losses and expenses including attorney's fees arising out of or resulting from the performance of the WORK. provided that any such claims, damage, loss or expense is attributable to bodily injury sickness, disease or death. or to injury to or destruction of tangible property including the loss of use resulting therefrom; and is caused in whole or in part by any negligent or willful act or omission of the CONTRACTOR, and SUBCONTRACTOR, anyone directly or indirectly employed by any of them or anyone for whose acts any of them may be liable.
- 24.2 In any and all claims against the OWNER or the ENGINEER, or any of their agents or employees, by any employee of the CONTRACTOR, any SUBCONTRACTOR, anyone directly or indirectly employed by any of them, or anyone for whose acts any of them may be liable, the indemnification obligation shall not be limited in any way by any limitation on the amount or type of damages, compensation or benefits payable by or for the CONTRACTOR or any SUBCONTRACTOR under workmen's compensation acts, disability benefit acts or other employee benefits acts.
- 24.3 The obligation of the CONTRACTOR under this paragraph shall not extend to the liability of the ENGINEER, his agents or employees arising out of the preparation or approval of maps, DRAWINGS, opinions, reports, surveys, CHANGE ORDERS, designs or SPECIFICATIONS.

### **25. SEPARATE CONTRACTS**

- 25.1 The OWNER reserves the right to let other contracts in connection with this PROJECT. The CONTRACTOR shall afford other CONTRACTORS reasonable opportunity for the introduction and storage of their materials and the execution of their WORK, and shall properly connect and coordinate his WORK with theirs. If the proper execution or results of any part of the CONTRACTOR'S WORK depends upon the WORK of any other CONTRACTOR, the CONTRACTOR shall inspect and promptly report to the ENGINEER any defects in such WORK that render it unsuitable for such proper execution and results.
- 25.2 The OWNER may perform additional WORK related to the PROJECT by himself, or he may let other contracts containing provisions similar to these. The CONTRACTOR will afford the other CONTRACTORS who are parties to such Contracts (or the OWNER, if he is performing the additional WORK himself), reasonable opportunity for the introduction and storage of materials and equipment and the execution of WORK, and shall properly connect and coordinate his WORK with theirs.
- 25.3 If the performance of additional WORK by other CONTRACTORS or the OWNER is not noted in the CONTRACT DOCUMENTS prior to the execution of the CONTRACT, written notice thereof shall be given to the CONTRACTOR prior to starting any such additional WORK. If the CONTRACTOR believes that the performance of such additional WORK by the OWNER or others involves him in additional expense or entitles him to an extension of the CONTRACT TIME, he may make a claim therefor as provided in Sections 14 and 15.

**26. SUBCONTRACTING**

- 26.1 The CONTRACTOR may utilize the services of specialty SUBCONTRACTORS on those parts of the WORK which, under normal contracting practices, are performed by specialty SUBCONTRACTORS.
- 26.2 The CONTRACTOR shall not award WORK to SUBCONTRACTOR(s), in excess of fifty (50%) percent of the CONTRACT PRICE, without prior written approval of the OWNER.
- 26.3 The CONTRACTOR shall be fully responsible to the OWNER for the acts and omissions of his SUBCONTRACTORS, and of persons either directly or indirectly employed by them, as he is for the acts and omissions of persons directly employed by him.
- 26.4 The CONTRACTOR shall cause appropriate provisions to be inserted in all subcontracts relative to the WORK to bind SUBCONTRACTORS to the CONTRACTOR by the terms of the CONTRACT DOCUMENTS insofar as applicable to the WORK of SUBCONTRACTORS and to give the CONTRACTOR the same power as regards terminating any subcontract that the OWNER may exercise over the CONTRACTOR under any provision of the CONTRACT DOCUMENTS.
- 26.5 Nothing contained in this CONTRACT shall create any contractual relation between any SUBCONTRACTOR and the OWNER.

**27. ENGINEER'S AUTHORITY**

- 27.1 The ENGINEER shall act as the OWNER'S representative during the construction period. He shall decide questions which may arise as to quality and acceptability of materials furnished and WORK performed. He shall interpret the intent of the CONTRACT DOCUMENTS in a fair and unbiased manner. The ENGINEER will make visits to the site and determine if the WORK is proceeding in accordance with the CONTRACT DOCUMENTS.
- 27.2 The CONTRACTOR will be held strictly to the intent of the CONTRACT DOCUMENTS in regard to the quality of materials, workmanship and execution of the WORK. Inspections may be made at the factory or fabrication plant of the source of material supply.
- 27.3 The ENGINEER will not be responsible for the construction means, controls, techniques, sequences, procedures, or construction safety.
- 27.4 The ENGINEER shall promptly make decisions relative to interpretation of the CONTRACT DOCUMENTS.

**28. LAND AND RIGHTS-OF-WAY**

- 28.1 Prior to issuance of NOTICE TO PROCEED, the OWNER shall obtain all land and rights-of-way necessary for carrying out and for the completion of the WORK to be performed pursuant to the CONTRACT DOCUMENTS, unless otherwise mutually agreed.
- 28.2 The OWNER shall provide to the CONTRACTOR information which delineates and describes the lands owned and rights-of-way acquired.
- 28.3 The CONTRACTOR shall provide at his own expense and without liability to the OWNER any additional land and access thereto that the CONTRACTOR may desire for temporary construction facilities, or for storage of materials.

**29. GUARANTY**

29.1 The CONTRACTOR shall guarantee all materials and equipment furnished and WORK performed for a period of one (1) year from the date of SUBSTANTIAL, COMPLETION. The CONTRACTOR warrants and guarantees for a period of one (1) year from the date of SUBSTANTIAL COMPLETION of the system that the completed system is free from all defects due to faulty materials or workmanship and the CONTRACTOR shall promptly make such corrections as may be necessary by reason of such defects including the repairs of any damage to other parts of the system resulting from such defects. The OWNER will give notice of observed defects with reasonable promptness. In the event that the CONTRACTOR should fail to make such repairs, adjustments, or other WORK that may be made necessary by such defects, the OWNER may do so and charge the CONTRACTOR the cost thereby incurred. The Performance BOND shall remain in full force and effect through the guarantee period.

**30. GOVERNING LAW AND DISPUTE RESOLUTION**

30.1 This Agreement will be governed by the laws of the State of Alabama.

30.2 The parties agree that all disputes between them shall first be submitted to mediation. All disputes, controversies or claims shall be subject to mediation as a condition precedent to the institution of legal or equitable proceedings by either party. Request for mediation shall be filed in writing with the other party to this Agreement and with the American Arbitration Association. The request may be made concurrently with the filing of legal or equitable proceedings, which shall be stayed pending mediation for a period of 60 days from the date of filing, unless stayed for a longer period by agreement of the parties or court order. The parties shall share the mediator's fee and any filing fees equally. The mediation shall be held at the Reservation of the Poarch Band of Creek Indians, unless another location is mutually agreed upon. Agreements reached in mediation shall be enforceable as settlement agreements in any court having jurisdiction thereof.

30.3 If the dispute cannot be so resolved, either Party may bring an action in a court of competent jurisdiction located in the first instance in the United States District Court for the Southern District of Alabama, and if, and only if, such court does not accept jurisdiction, then in the Circuit Court of Coffee County, Alabama.

30.4 The CONTRACTOR will carry on the WORK and maintain the progress schedule during any mediation or litigation, unless otherwise mutually agreed in writing.

**31. TAXES**

31.1 The CONTRACTOR will pay all sales, consumer, use and other similar taxes required by the law of the place where the WORK is performed.

## SUPPLEMENTAL GENERAL CONDITIONS

### 1. INSURANCE

- 1.1 The Contractor shall provide umbrella form general liability coverage with a limit of liability of not less than \$1,000,000 which applies to general and automobile liability coverage.

### 2. PROTECTION OF OWNER

- 2.1 The Contractor hereby agrees to hold harmless, indemnify and defend the Owner, the Owner's agent, the Consulting Engineer, and the Owner's employees while acting within the scope of their duties from and against any and all liability, claims, damages, and cost of defense arising out of the Contractor's performance of the work described herein but not including the sole negligence of the Owner, his agents or employees. The Contractor will require any and all subcontractors to conform with the provisions of this clause prior to commencing any work. **The Contractor shall furnish an Owner's Protective Liability Policy which lists both the Owner and the Engineer as Named Insured.** This insurance coverage shall be provided in a policy separate from the Contractor's insurance policies, and a copy of the policy shall be provided to the Engineer. The limits of liability shall be not less than \$1,000,000.

### 3. ADVERTISEMENT OF CLOSING

- 3.1 The Contractor shall attach to the final payment estimate an affidavit of publication (with clipping) from a newspaper of general circulation in the county where work was done, that completion has been advertised weekly for four consecutive weeks. First notice must be subsequent to completion. Employ the following copy:

"Notice is hereby given that (contractor and address) has completed all work on the **FY 2023 RAA STREET RESURFACING AND REPAIRS** in **Jackson, Alabama.**" All persons having any claim for labor, materials, or otherwise in connection with this project should immediately notify the above named contractor and the City Clerk of the City of Jackson.

### 4. SUBCONTRACTING

- 4.1 The Contractor shall not award work to subcontractor(s) in excess of fifty (50%) percent of the contract price, without prior written approval of the Owner.

### 5. TIME FOR COMPLETION AND LIQUIDATED DAMAGES

ARTICLE 15 of the GENERAL CONDITIONS is hereby revised to read as follows:



- 5.1 It is hereby understood and mutually agreed, by and between the Contractor and the Owner, that the date of beginning and the time for completion as specified in the contract of the work to be done hereunder are ESSENTIAL CONDITIONS of this Contract; and it is further mutually understood and agreed that the work embraced in this Contract shall be commenced on a date to be specified in the "Notice to Proceed."
- 5.2 The Contractor agrees that said work shall be prosecuted regularly, diligently and uninterruptedly at such rate of progress as will insure full completion thereof within the time specified. It is expressly understood and agreed, by and between the Contractor and the Owner, that the time for the completion of the work described herein is a reasonable time for the completion of the same, taking into consideration the average climatic range and usual industrial conditions prevailing in this locality.
- 5.3 If the said Contractor shall neglect, fail or refuse to complete the work within the time herein specified, or any proper extension thereof granted by the Owner, then the Contractor does hereby agree, as a part consideration for the awarding of this Contract, to pay to the Owner the amount specified in the Contract, not as a penalty but as liquidated damages for such breach of contract as hereinafter set forth, for each and every calendar day that the Contractor shall be in default after the time stipulated in the Contract for completing the work.
- 5.4 The said amount is fixed and agreed upon by and between the Contractor and the Owner because of the impracticability and extreme difficulty of fixing and ascertaining the actual damages the Owner would in such event sustain, and said amount is agreed to be the amount of damages which the Owner would sustain and said amount shall be retained from time to time by the Owner from current periodical estimates.
- 5.5 It is further agreed that time is of the essence of each and every portion of this Contract and the specifications wherein a definite and certain length of time is fixed for the performance of any act whatsoever; and where under the Contract an additional time is allowed for the completion of any work, the new time limit fixed by such extension shall be of the essence of this Contract. Provided, that the Contractor shall not be charged with liquidated damages or any excess cost when the Owner determines that the Contractor is without fault and the Contractor's reasons for the time extension are acceptable to the Owner; provided, further, that the Contractor shall not be charged with liquidated damages or any excess cost when the delay in completion of the work is due:
- 5.5.1 To any preference, priority or allocation order duly issued by the Government.
- 5.5.2 To unforeseeable cause beyond the control and without the fault or negligence of the Contractor, including, but not restricted to, acts of God, or of the public enemy, acts of the Owner, acts of another Contractor in the performance of a contract with the Owner, fires, floods, epidemics, quarantine restrictions, strikes, freight embargoes and severe weather.
- 5.5.3 To any delays of Subcontractors or suppliers occasioned by any of the causes specified in subsections (a) and (b) of this article.

5.6 Provided, further, that the Contractor shall, within ten (10) days from the beginning of such delay, unless the Owner shall grant a further period of time prior to the date of final settlement of the Contract, notify the Owner, in writing, of the causes of the delay, who shall ascertain the facts and extent of the delay and notify the contractor within a reasonable time of its decision in the matter.

## 6. **PAYMENTS TO CONTRACTOR**

Portions of ARTICLE 19 of the GENERAL CONDITIONS are revised to read as follows:

6.1 The OWNER shall retain five (5) percent of the amount of each payment until the project is fifty (50) percent complete after which no further retainage shall be withheld. The retainage stated above shall be held by the OWNER until final completion and acceptance of the work, and meet all conditions of the Contract.

6.2 Prior to final payment, a NONRESIDENT CONTRACTOR shall satisfy the OWNER that he or she has paid all taxes due and payable to the State of Alabama or any political subdivision thereof. For the purpose of this Article, a NONRESIDENT CONTRACTOR is one who is neither (a) organized and existing under the laws of the State of Alabama, nor (b) maintains its principal place of business in the State of Alabama. A NONRESIDENT CONTRACTOR which has maintained a permanent branch office within the State of Alabama for at least five continuous years shall no thereafter be deemed to be NONRESIDENT CONTRACTOR so long as the Contractor continues to maintain a branch office within Alabama.

6.3 Final Payment shall be made to the Contractor no less than 10 days following receipt by the Owner of:

1. A properly executed, and duly certified payment estimate.
2. A release of all claims filed against the Contractor, or claims of lien filed against the Owner, arising under or by virtue of the Contract or completed work.
3. A proof of advertisement of project completion. However the final payment shall not be made until the expiration of thirty days after completion of the advertisement.
4. For NONRESIDENT CONTRACTORS, proof of payment of all taxes due the State of Alabama, or any political subdivision thereof.

6.4 Only those portions of ARTICLE 19 of the GENERAL CONDITIONS which conflict with the Articles above are revised. All other portions of Article 19 shall remain as stated in the GENERAL CONDITIONS.

## 7. **CONTRACT SECURITY**

7.1 ARTICLE 22 of the GENERAL CONDITIONS of the Contract are revised such that the amount of the PAYMENT BOND will not exceed 50% of the Contract Price.

8. **ASSIGNMENT**

8.1 ARTICLE 23 of the GENERAL CONDITIONS is hereby revised to include the following:

Under no circumstances shall a contract be assigned to an unsuccessful bidder whose bid was rejected because he or she was not a responsive bidder.

9. **DOMESTIC PRODUCTS AND STEEL**

9.1 The Contractor to whom the Construction Contract is awarded shall use materials, supplies, and products manufactured, mined, processed, or otherwise produced in the United States or its territories, if the same are available at reasonable and competitive prices, and are not contrary to any sole source specification included in the Contract.

9.2 The Contractor shall use steel produced within the United States when the specifications require the use of steel, and do not limit its supply to a sole source.

9.3 The Contractor shall provide the Owner a certification that only domestic products and steel will be used in the completion of the work subsequent to the contract. The Certification shall be provided prior to the execution of the contract, and shall be executed by the same person who executes the Contract on behalf of the Contractor, and shall be notarized. The Contractor shall also provide copies of similar certifications from material and equipment suppliers as a part of any submittals presented to the Engineer for approval.

9.4 In the event the Contractor violates the agreement to use domestic or steel, and domestic products or steel are not used, there shall be a downward adjustment in the contract price equal to any realized savings or benefits to the Contractor.

10. **COMPLIANCE WITH PL 91-596 AND PL 91-54**

10.1 The Contractor shall comply with the Department of Labor Safety and Health Regulations for construction promulgated under the Occupational Safety and Health Act of 1970 (PL 91-596) and under section 107 of the Contract Work Hours and Safety Standards Act (PL 91-54).

11. **EXPERIENCE CLAUSE**

11.1 The general use of experience clauses requiring equipment manufacturers to have a record of satisfactory operation for a specific period of time or bonds or deposits to guarantee replacement in the event of failure is restricted to special cases where the grantee's engineer adequately justifies any such requirement in writing. Where such justification has been made, submission of a bond or deposit shall be permitted in lieu of a specified experience period, and the period of time for which such bond or deposit is required

should not exceed the period specified.

**SPECIAL SPECIFICATIONS  
FOR  
STREET RESURFACING & REPAIRS  
CITY OF JACKSON, ALABAMA**

**1. GENERAL**

- 1.1 The work to be done under this Contract includes the construction of Storm Drainage Improvements and Resurfacing of miscellaneous streets in Jackson, Alabama. The City opened bids to replace the water main along this street on February 23, 2023.
- 1.2 When no bid item is provided for work described by the plans or these specifications, the work shall be considered incidental to the project and the cost shall be included in other items of work provided in the Proposal.
- 1.3 Any work under this Contract not specifically covered by the Plans or these Specifications shall comply with the applicable sections of the State of Alabama Department of Transportation Standard Specifications for Highway Construction (ALDOTSSHC), Latest Edition.

**2. ASBUILTS**

- 2.1 The Contractor shall be responsible for providing a full set of as-built drawings to the Engineer upon completion of the project. All costs associated with providing these as-builts on a clean set of plans shall be included in the unit prices bid. No additional payment will be made to the Contractor for providing these as-builts. The as-builts should be made at the same rate as construction and should at a minimum show the placement of the storm sewers, locations of all inlets, ditch grading and valley gutter. In showing the placement of the above-mentioned items on the plans, the Contractor shall at a minimum locate these items with measurements from at least two prominent features (i.e. – site-built house corners, fire hydrants, power poles, etc.) and the two adjacent sewer main manhole covers. Final payment of retainage will be withheld until the As-Builts are received in satisfactory condition by the Engineer.

**3. TIME FOR COMPLETION, LIQUIDATED DAMAGES, & WORK SCHEDULE**

- 3.1 The Contractor must commence work on or before a date to be specified in a written "Notice to Proceed" issued by the Owner and must fully complete the project within **sixty (60)** consecutive calendar days thereafter. For each calendar day thereafter, the Contractor shall be subject to a charge of \$500.00 per day as liquidated damages.
- 3.2 The Contractor shall notify the Engineer at least 48 hours prior to performing any work in order that arrangements can be made for a construction observer to be on site during the construction.
- 3.3 The time for completion of this Contract is based on a standard weekly work schedule of Monday through Friday. No work shall be scheduled or performed on Saturday, Sunday, or holidays, except

for any required emergency maintenance work, without the prior approval of the Engineer.

#### **4. SUBCONTRACTING**

- 4.1 The Contractor shall not subcontract more than 50% of the contract work without written permission of the Owner. The Owner shall approve all subcontractors. Prior to beginning any work on the contract, the Contractor shall submit a list of all subcontractors along with a description of the work planned for each subcontractor; a list of previous projects completed; a list of references; a list of the subcontractor's equipment to be used on the project; a list of credit references; and a copy of the proposed contract between the prime contractor and subcontractor.
- 4.2 No subcontractor will be approved for work on this Contract who cannot demonstrate ability to satisfactorily complete the work.

#### **5. EQUIPMENT AND MATERIAL**

- 5.1 Shop drawings, data and material specifications, schedules of pipe materials and manufacturers' affidavits of certification for all equipment and material selections shall be submitted to the Engineer for review and approval prior to the purchase, delivery, or installation of any equipment or materials.
- 5.2 No products or equipment shall be delivered or unloaded until the Engineer has reviewed and approved material submittal data. Any materials found damaged shall be removed from the site and replaced by the Contractor at no cost to the Owner.
- 5.3 All products shall be stored in accordance with manufacturers' recommendations. Products shall not be stored in direct sunlight or where there is possibility of contact with fire or excessive heat and shall not be stored in areas which would endanger safety of public or construction operators or result in damage to products. The Contractor shall provide proper and suitable tools and appliances for safe handling of products and shall use care to ensure the products are not damaged or compromised in integrity of operation or appearance throughout the work and until final acceptance of the entire project. Products and pipe materials shall be kept clean and free of dirt and debris throughout the project's completion. Any products found damaged or not clean shall be replaced by the Contractor at no expense to the Owner.

#### **6. EXISTING UTILITIES AND UNDERGROUND OBSTRUCTIONS**

- 6.1 In excavating and backfilling care must be taken not to remove, disturb or injure any water, sewer, gas, electric, telephone, or other conduits or utilities encountered without prior approval of the Owner of the utility, including private utilities. If necessary, to perform the intended work, the Contractor shall sling, shore up, and maintain such utilities in operation, and promptly repair any damage done to them. Before final acceptance of the work, all such utilities shall be made "equal or better" than prior to construction.

- 6.2 It shall be the Contractor's responsibility to give sufficient prior information to the utility owner that construction will take place whereby the utility owner will be afforded an opportunity to adequately mark, on the ground or with sufficient maps, the utility locations. Coordination of such information and utility locations shall be the sole responsibility of the Contractor. In event of damage to the utilities, the Contractor will promptly notify the utility owner (private or public) and must assume full responsibility thereof. Failure of the Contractor to promptly notify the utility owner shall make him liable for any needless loss or interference with normal operations of the utility.
- 6.3 In the event that pipes or conduits providing service to adjoining buildings are broken, or damaged to some questionable degree of service, the Contractor shall immediately make repairs at his own expense or be otherwise liable for repair costs incurred by others. Delays which would result in service being off overnight or needlessly for long periods during the day will not be tolerated. The utility owner reserves the right to make repairs, to utilities or structures damaged by the Contractor, without prior notice. Removal or relocation of a utility encountered may be done upon prior approval by the utility owner give directly to the Contractor.
- 6.4 Prior to construction and/or bidding, the Contractor shall satisfy himself as the underground obstructions by making direct contact with utility firms, if he so desires, to become thoroughly aware of true conditions. The utility lines shown on the plans and any notes on the plans pertaining to underground obstructions were taken from those records available for the system, and there was no intent to show the details and locations of all underground obstructions which may be encountered. The information shown is for the Contractor's convenience only, and it shall not be used as a basis for claims for extra compensation.

## **7. ACCIDENT PREVENTION, SAFETY, AND PROTECTION OF PROPERTY**

- 7.1 The Contractor will be responsible for initiating, maintaining, and supervising all safety precautions and programs in connection with the work. The Owner will require that caution shall be exercised by the Contractor at all times for the protection of persons (including employees) and property and he shall comply with the safety provisions of all applicable laws and building codes. The Contractor shall comply with all applicable OSHA criteria and shall maintain a safety program as outlined in the Manual of Accident Prevention in Construction published by the Associated General Contractors of America.
- 7.2 The Owner and its Engineer, including the construction observer, do not inspect safety. The Contractor and he alone shall be liable for any claims or lawsuits made or filed in connection with damages, injuries, loss of life or other accidents caused by his construction operations or due to his negligence or to the negligence of his employees in taking proper and adequate precautions to insure the safety of the general public, his own employees, or any other person or property, or due to unforeseen accidents incident to the work such as trench cave-ins, ruptured utility lines and conduits, etc. The Contractor shall indemnify and save harmless the Owner, the Owner's Engineer, and all other agents, officials, or employees of the Owner, against any claims or lawsuits made or filed against him in connection with his work under this contract.
- 7.3 Prior to beginning construction work, the Contractor shall thoroughly document the condition of all existing landscaping, structures, and other improvements which may be affected by his operations. The manner in which documentation is accomplished shall be acceptable to the Engineer but as a

minimum, shall include a color video tape(s) of the construction area. A complete set of documentation will be available on the job site to help determine what restoration work is required to return any disturbed property to its original condition and to settle disputes concerning the original conditions of any property.

**8. STORMWATER**

8.1 In accordance with NPDES regulations, stormwater construction best management practices (CBMPs) shall be observed and applied on this project. The Contractor shall adhere to all regulations and CBMP requirements. The Contractor will be expected to implement said practices to ensure no erosion resulting in off-site siltation or sedimentation occurs. All costs for implementing these practices, (i.e., grassing, installing silt fence, mulch, etc.), shall be included in the various items of work included in the Proposal. Requirements for implementing and maintaining acceptable BMPs shall be the sole responsibility of the Contractor.

**9. MOBILIZATION**

9.1 This section shall cover the preparatory work including the movement of personnel, equipment, supplies and incidentals to and from the project site, and other costs incurred prior to beginning work. Payment for this line item shall be limited to 5% of the total bid amount.

**10. PIPE REMOVAL**

10.1 This item shall cover the saw cutting and removal of existing stormwater pipe and all other items as necessary to remove the pipe including but not limited to earthwork.

10.2 Payment for removal of the existing pipe will be made at the linear foot price bid in the Proposal for **Pipe Removal** and shall include all labor, equipment and materials required to complete the required work.

**11. UNCLASSIFIED EXCAVATION**

11.1 This item shall cover the excavation of existing material that is deemed unsuitable by the Engineer and other miscellaneous excavation required to bring the sub-grade to the desired grade or elevation as required by the Engineer. All excess soil material that is not used for fill material shall become property of the Contractor and be removed from the jobsite. The excavation used for backfill shall be placed in maximum 8" loose lifts and shall be compacted by an approved method of tamping to 100% of ASTM D-698 Specification for the Standard Proctor Density Test.

11.2 Payment for this work will be made at the contract unit price per cubic yard for **Unclassified Excavation** for the amount of material cut and shall cover the excavation and replacement of material including all labor, equipment, tools, materials and incidentals required to excavate and replace or remove the material as specified or directed. Unclassified excavation shall be carried out in accordance with Section 210 of the ALDOTSSHC.



**12. CURB AND GUTTER**

- 12.1 All curb and gutter shall be installed in accordance with ALDOT Standard Specification for Highway Construction (ALDOTSSHC), Latest Edition and details shown on the plans. All costs to install the curb and gutter shall be paid for under the unit price line item for **Concrete Curb and Gutter**.

**13. ASPHALT SAWCUTTING/REMOVAL**

- 13.1 The Contractor must sawcut and remove pavement as necessary (6" Max Offset) to ensure a smooth and continuous grade to construct the required valley gutter. It is the sole responsibility of the Contractor to maintain the pavement edge once it has been sawcut. Any removal of bituminous pavement and materials to establish subgrade depth for valley gutter (within the maximum 6" offset) will be paid for at the contract unit price for **Asphalt Sawcutting/Removal**.

**14. SELECT BACKFILL**

- 14.1 Where directed by the Engineer, the Contractor shall backfill streets with select backfill. The select backfill shall be from a source as approved by the Engineer and will be paid for on a cubic yard basis, truck measure. The backfill shall be placed in maximum 6" loose lifts and shall be compacted by an approved method of tamping to 95% of AASHTO T-99 Specification for the Standard Proctor Density Test. The Contractor shall provide any necessary equipment required to properly compact the ditch lines and this compaction work shall be accomplished in accordance with all applicable OSHA requirements.
- 14.2 Select backfill shall be a free-draining local material suitable for use as foundation or backfill for drainage structures. The Contractor shall uniformly deposit the material across the full width of the excavation in layers not to exceed six (6) inches in thickness and shall compact each layer as directed by the Engineer. Select backfill shall replace existing material that is unsuitable to serve as structure foundation. The volume of select backfill shall be measured based upon the truck loads of material ordered by the Engineer. Payment for the material shall be made at the contract unit price bid for **Select Backfill** and shall be full compensation for the item complete in place, including disposal of unsuitable material.

**15. MINOR STRUCTURE CONCRETE**

- 15.1 The item in the proposal for **Minor Structure Concrete** is intended to cover the construction of miscellaneous structures such as small drainage flumes, curb tie-ins and any other additional required special structures. Measurement and payment for the special structures will be made at the contract unit price bid per cubic yard for Minor Structure Concrete. Payment will be for all labor, material, reinforcement, equipment and for excavating, grading, forming, placing, finishing and all other incidental work to furnish the structures complete in place. The concrete shall be 3,000 psi, with concrete engineered reinforcing fibers as specified in the Specifications.

**16. CRUSHED STONE BACKFILL**

16.1 Crushed Stone backfill shall be **crushed limestone** suitable for use as foundation for pipe and drainage structures which meets the gradation standards for No. 57 coarse aggregate, and Section 801.03 and 801.11 of the ALDOTSSHC, Latest Edition. The Contractor shall uniformly deposit the gravel across the full width of the excavation in layers not to exceed six (6) inches in thickness and shall compact each layer as directed by the Engineer. Crushed Stone backfill shall replace existing material that is unsuitable to serve as structure foundation and for bedding around HDPE pipe. Payment for the calculated cubic yards of material will be made at the contract unit price for ***Crushed Stone Backfill*** which shall be full compensation for the item complete in place.

**17. RIPRAP**

17.1 The work covered by this section consists of installing stone riprap on the drainage slope as shown in the plans. The stone riprap shall be Class 2 as specified in Section 814 of the ALDOT Standard Specifications for Highway Construction, latest edition.

17.2 The area to receive the riprap shall be graded to the lines and slopes shown on the plans or as directed by the Engineer. The riprap shall be placed in accordance with Section 610 of the ALDOT Standard Specifications for Highway Construction, latest edition.

17.3 Prior to placing the riprap, the Contractor shall install a geotextile filter blanket. A 2" layer of No. 57 stone shall be installed on top of the filter fabric to prevent damage to the fabric during placement of the riprap. The Owner or Engineer shall inspect the 2" thick aggregate layer before placement of any riprap on top of it.

17.4 Payment for ***Riprap, Class 2*** will be made at the unit price bid in the Proposal, per ton, and shall be full compensation for labor, equipment and incidentals required to complete the work, including filter fabric and #57 stone.

**18. ASPHALT**

18.1 Any work under this Contract not specifically covered by the Plans or these Specifications shall comply with the applicable sections of the ALDOTSSHC, Latest Edition.

18.2 As a part of the replacement of the storm system improvements, crushed roadway stone shall be applied to the top of the trench lines within the street. Prior to initiating any resurfacing work, this roadway stone shall be smoothed and compacted as necessary to provide a proper surface for the placement of an asphalt leveling course across the trench lines.

18.3 On those streets, or portions of streets to be resurfaced, the trench lines shall receive a leveling course of bituminous plant mix applied in accordance with these Specifications. The entire street shall then be completely resurfaced.

- 18.4 At the request of the Engineer, the Contractor shall provide the necessary equipment and personnel to cut samples from the compacted pavement for testing. Samples not smaller than four inches square or four inches in diameter for the full depth of the course to be tested shall be taken at the locations directed by the Engineer. Furnishing of suitable, approved cutting equipment, the cutting of the samples, and the immediate repair of the sample holes with similar material shall be performed by the Contractor without extra compensation.
- 18.5 The quantity of asphalt leveling course and bituminous concrete wearing surface placed as directed by the Engineer will be measured in tons of 2,000 pounds. Payment will be made on tonnage basis and the contract unit price per ton shall be full compensation for construction of the bituminous wearing surface complete in place on the roadbed as directed, including all materials, procurement, handling, hauling, and processing cost, and includes all equipment, tools, labor, and incidentals required to complete the work. The cost of the clipping shall be included in the unit price bid for the wearing surface.
- 18.6 At the locations as directed by the Engineer, the Contractor shall install asphalt driveway turnouts with a minimum length of approximately 12 feet and a width of 3 feet. The cost of installing the turnouts shall be included in the unit price bid for the bituminous wearing surface.
- 18.7 The Contractor shall submit a mix design for the bituminous concrete wearing surface that has been approved by the State. This mix design shall be submitted to and be approved by the Engineer prior to placing any asphalt on the job.
- 18.8 Locations for the pavement repair section shall be decided in the field with the Engineer during construction.

## **19. STORM SEWERS**

- 19.1 The Contractor shall furnish and install storm sewers or roadway pipe culverts as shown on the plans. All storm drainpipes shall be Class III or Class IV Reinforced Concrete Pipe with O-Ring Joints meeting ASTM Standard Specifications C-76 and C-443; or type S, double wall, smooth interior, corrugated polyethylene pipe meeting AASHTO Specification M294. Pipe Joint lubricant shall be installed in accordance with the manufacturer's recommendation for concrete pipe. Lift holes **shall not** be allowed in the pipe. Payment for the providing and installing the pipe will be made at the contract unit price per linear foot for the pipe and accepted, including installation and backfill, and shall be full compensation for all materials, labor, tools, equipment and other incidentals necessary to construct the drainage pipe as specified herein.

## **20. DRAINAGE STRUCTURE**

- 20.1 The Contractor shall install drainage structures in accordance with the details shown in the Plans. The actual construction of the structures at the various locations may be altered as required to adequately collect the stormwater and fit each particular application. The structural details in the plans show the general arrangement of the proposed structures; however, it may be necessary to alter the exact arrangement of these details upon their actual construction. Payment for these drainage structures will be made at the contract price set-up in the proposal for each **Drainage**

**Structure** completed and accepted, and shall be full compensation for all materials, labor, tools, equipment and other incidentals required to construct the drainage inlets as specified herein. There will be no additional compensation made for the construction of said drainage inlets due to any alterations in their arrangement or layout. In addition, reinforcing must be placed per the Engineer.

**21. TOPSOIL**

- 21.1 Topsoil shall be provided and installed by the Contractor at locations as shown on the Plans and/or as directed by the Engineer. The topsoil shall be spread approximately four to six inches thick, lightly compacted into place, and graded to provide a smooth finished surface free of rocks, roots and debris. Topsoil provided from an off-site source will be paid for on a cubic yard basis, truck-bed measure. Topsoil provided from on-site stripping and subsequent stockpiles will be paid for under the pay item **Topsoil**.

**22. TRAFFIC CONTROL MARKINGS AND SIGNS**

- 22.1 The Contractor shall be required to stripe as shown in the plans and in accordance with Section 703 of the ALDOTSSHC, Latest Edition. Payment for Traffic Control Markings will be made on a per linear foot and shall include all labor, equipment, materials, and incidentals required to complete the work.

**23. TRAFFIC CONTROL IN WORK AREAS**

- 23.1 During construction work along City streets, the Contractor shall comply with the applicable provisions of Part VI of the Federal Manual on Uniform Traffic Control Devices, latest edition. The Engineer, in performance of his duties outlined in these Specifications does not guarantee or ensure the Contractor's compliance with these regulations.
- 23.2 The Contractor shall keep both the Police Department and Fire Department informed of the areas in which they are working and notify them on a daily basis of all work that will partially block or close streets.
- 23.3 The Contractor shall notify all homeowners prior to work in their driveways. The homeowner shall have access to their residence at all times.
- 23.4 Payment for Traffic Control will be made at the lump sum price bid in the Proposal for **Traffic Control** and shall include all labor, equipment and materials required to complete the required work.

**24. CLEAN-UP, GRASSING AND SEEDING**

- 24.1 Throughout the progress of the work, the Contractor shall keep the construction area, including storage areas used by him, free from accumulations of waste material or rubbish. Disposal of all waste materials shall be at locations satisfactory to the Engineer.
- 24.2 Where the Contractor has performed work on or has made use of private property for storage of materials or for other purposes, he shall obtain a satisfactory release from the owner of said property after completion of the work and the removal of all materials and equipment therefrom.
- 24.3 The work site shall be cleaned up on a daily basis. Prior to stopping work for the day, the ditch lines shall be backfilled and tamped.
- 24.4 The Contractor shall be responsible for the daily maintenance of all ditch lines and street crossings on paved streets until such time as the paving can be replaced. This maintenance shall include any measures necessary to control excessive dust. The streets shall be maintained such that they can be conveniently and safely utilized by the public.
- 24.5 All trees and shrubbery shall be protected from damage at all times. Should, by accident or otherwise, such trees or shrubbery be damaged, they shall be repaired by personnel trained in this type of repair work at the Contractor's expense.
- 24.6 Existing driveways, which have a gravel or slag surfacing, shall have the gravel or slag replaced such that the driveways are restored to their original condition. Any labor and materials required to restore these driveways shall be included in the unit prices bid in the proposal. All driveways shall be tamped to prevent settlement and any labor and materials required to maintain the driveways in a serviceable condition shall be provided and paid for by the Contractor.
- 24.7 It is the intention of the Engineer to Sod all of the areas which have significant slope and to mulch/grass the balance of the disturbed areas. Specific direction shall be given to the Contractor by the Owner/Engineer during sodding & seeding as to the actual placement of said items.
- 24.8 Upon completion of construction on each section, the disturbed areas shall be grassed/sodded as soon as practicable. The Contractor will not be allowed to wait until the entire project is complete to perform the required grassing work.
- 24.9 The work under this section shall cover the furnishing, planting or otherwise re-establishing solid grass sodding in accordance with ALDOT Standard Specifications for Highway Construction, latest edition. The sod shall be similar to that of the surrounding area and shall be placed at the locations as directed by the Engineer. If necessary, the sod shall be staked in order to prevent sliding as directed by the Engineer. The cost of staking the sod as directed by the Engineer will be considered incidental to the work and will merit no additional compensation.
- 24.10 All areas to receive sod shall be limed and fertilized with 2.0 tons/acre of agricultural limestone and 500 pounds/acre of 13-13-13 commercial fertilizer. The lime and fertilizer shall be thoroughly worked into the soil, and the surface smoothed to remove high and low areas. The sod shall be machine cut with a uniform soil thickness of 5/8 inch, plus or minus 1/4 inch. Sod shall not be harvested, delivered, and transplanted when moisture conditions may adversely affect its survival. The sod shall be relatively free of thatch, and it shall contain not more than 10 weeds per 100 square feet. The first row of sod shall be laid in a straight line with subsequent rows placed parallel to and tightly against each other, while staggering the lateral joints. The Contractor shall water sod

immediately after transplanting and as soon as sodding is completed in any one section, the entire area shall be rolled and thoroughly watered. The Contractor shall be responsible for watering the sod sufficiently to keep it in a living and growing condition until all work has been completed and accepted.

- 24.11 All disturbed areas shall be mulched and seeded. The mulching and seeding shall be performed in accordance with the ALDOT Standard Specification for Highway Construction (ALDOTSSHC), Latest Edition. The areas to be seeded shall receive 2.0 tons per acre of agricultural limestone and 400 pounds per acre of 13-13-13 commercial fertilizer. The lime and fertilizer shall be thoroughly disked into the soil and the soil prepared for seeding. The mulching shall be performed in accordance with ALDOTSSHC, Section 656, and the seeding in accordance with Section 652 of ALDOTSSHC. Seed mix 3E shall be utilized. The mulch shall either be Class A, type 1; or Class A Type 2 depending on the slope of the surface to be seeded.
- 24.12 Erosion control netting blanket shall be installed at the locations designated by the Engineer to reduce erosion and aid in establishing a proper stand of grass. The erosion control fabric shall be E208 medium excelsion blanket as manufactured by GeoTech Environmental Systems or approved equal. Erosion control blanket shall be furnished and installed, measured by the square yard of finished surface with no allowance made for overlaps. The blanket shall meet the following specifications:

The blanket shall consist of wood excelsior fiber made into a blanket. The top and bottom side of the standard blanket shall be covered with a degradable synthetic mesh that is adhered to the excelsior by a knitting process using degradable thread. The blanket shall be covered with a degradable synthetic mesh on top and bottom sides.

Width (min)	7.5 feet (2.3m)
Length	96 feet
Weight per roll	80 lbs.
Volume per roll	80 sq. yds. (Coverage)

“U” shaped staples shall be made of 11 gauge or heavier steel wire and shall have 6-inch legs and a 1-inch crown.

- 24.13 The area to be covered with erosion control blanket shall be seeded before the blanket is placed. When the mat is unrolled, the netting shall be on top and fibers shall be in contact with soil. The end of the upslope blanket shall overlap the buried end of the downslope blanket a maximum of 8 inches and a minimum of 4 inches, forming a junction slot. This junction slot shall be stapled across 8-inch intervals, alternating the center row so that the staples form an “X” pattern. A common row of staples shall be used on adjoining blankets. Overlaps shall be limited to one for each 6 feet of width. The Contractor shall maintain the blanket until all work has been completed and accepted. Maintenance shall consist of the repair of areas where damaged by any cause. All damaged areas shall be repaired to reestablish the condition and grade of the soil prior to application of the covering and shall be refertilized, reseeded, and remulched as directed.
- 24.14 Payment for all items required in these Sections, including, but not limited to, ground preparation, lime, fertilizer, seeding and mulching shall be made at the lump sum price bid in the Proposal for

***Cleanup, Grassing and Seeding*** and shall include all labor, equipment and materials required to complete the required work.

**25. EROSION CONTROL**

25.1 Where directed by the Engineer, the Contractor shall provide, establish, and maintain temporary measures as necessary to control sedimentation and erosion. These measures should be in place prior to and during any construction activity and may include, at a minimum, silt fencing and wattles. Silt fence and wattles shall be provided in accordance with Alabama Department of Transportation Standard Specifications for Highway Construction (ALDOTSSHC), Latest Edition. Payment for erosion control will be made at the lump sum price bid in the Proposal for ***Erosion Control*** and shall include all labor, equipment and materials required to complete the required work.

**26. MATERIALS TESTING**

26.1 The cost of all soils, concrete and asphalt field and laboratory testing deemed necessary by the Engineer, other than the design mixes (which are required), will be paid for by the Materials Testing cash allowance item included in the Proposal. The amount of this cash allowance will be adjusted to reflect the actual cost of this testing work and all testing shall be performed by the Engineer or the Engineer's subcontractor(s). The Contractor will help the materials testing personnel in obtaining the necessary samples of soil and asphalt.

26.2 The Engineer or his authorized representative will select locations for all tests to be conducted. A cash allowance has been set up in the Proposal to cover the cost of all testing. The Engineer will provide invoices to the Contractor for the costs of all testing (up to the amount of the cash allowance) and the Contractor shall include such cost in his monthly payment requests.

26.3 Copies of all test results will be furnished to the Contractor as soon as they are available. Any areas found by the testing to be deficient in any way will be retested after the Contractor corrects the deficiency, unless otherwise directed by the Engineer.

**27. MISCELLANEOUS**

27.1 The Contractor shall abide by all local and State laws or ordinances to the extent that such requirements do not conflict with Federal laws or regulations. The Contractor shall be responsible for the purchase of all licenses and permits required by the City, County, State or Federal government, and shall comply with all laws, ordinances, or regulations of those governments in pursuance of the work spelled out in this contract.

27.2 A local building permit will not be required for this job. The Contractor and any subcontractors will be required to have current local contractor's licenses.

27.3 All contractors should note the requirements of Sections 11 and 12 of the Supplemental General Conditions concerning insurance requirements for this work, no exceptions will be taken.

- 27.4 No work shall be initiated on this project until the Contractor has all equipment on the job that is required to clean up and properly maintain the site. No work will be done in the streets until the Contractor has the necessary mechanical compaction equipment on-site to satisfactorily compact the ditch lines.
- 27.5 The Contractor is encouraged to remain inside the limits of the designated construction area to minimize damage to the existing grassed areas. Unnecessary damage to grassed areas outside of the limits of construction may be subject to repair by the Contractor with no reimbursement for the work performed.
- 27.6 The items in the Proposal are intended to provide full compensation to the Contractor for providing a complete and functional Stormwater System in place for the unit prices bid. Payment for any minor items necessary to satisfactorily complete the project which are not listed in the Proposal shall be included in the prices bid in the Proposal. No additional payment will be made for these minor items.

END OF SECTION



**GENERAL SPECIFICATIONS  
FOR  
STORMWATER DRAINAGE**

**1. STORMWATER**

- 1.1 The Contractor shall furnish and install storm sewers and roadway pipe culverts as shown on the plans. All storm drain pipe shall be Class III or Class IV Reinforced Concrete Pipe with O-Ring Joints meeting ASTM Standard Specifications C-76 and C-443. Construction requirements shall be done in accordance with Section 840 of the ALDOTSSHC, latest edition. Pipe Joint lubricant shall be installed in accordance with the manufacturer's recommendation. Lift holes shall not be allowed in the pipe. All costs for materials, excavation, installation and backfill shall be included in the contract unit price for pipe per linear foot.

**2. DRAINAGE STRUCTURES**

- 2.1 The Contractor shall construct reinforced concrete drainage inlets and other structures in accordance with the details shown in the Plans. The actual construction of the inlets and other storm drainage structures at the various locations may be altered as required to adequately collect and fit each particular application. The structural details in the plans show the general arrangement of the proposed structures; however, it may be necessary to alter the exact arrangement of these details upon their actual construction. Payment for these drainage structures will be made at the contract price set-up for minor structure concrete and shall be full compensation for all materials, labor, tools, equipment and other incidentals required to construct the drainage structures as specified herein. There will be no additional compensation made for the construction of said Storm Drainage Structures due to any alterations in their arrangement or layout. In addition, reinforcing must be placed per the Engineer.

**3. CRUSHED STONE BACKFILL**

- 3.1 Crushed Stone backfill shall be crushed limestone suitable for use as foundation for drainage structures which meets the gradation standards for No. 57 coarse aggregate, and Section 801.03 and 801.11 of the ALDOTSSHC, Latest Edition. The Contractor shall uniformly deposit the gravel across the full width of the excavation in layers not to exceed six (6) inches in thickness and shall compact each layer as directed by the Engineer. Crushed Stone backfill shall replace existing material that is unsuitable to serve as structure foundation. Payment for the calculated cubic yards of material will be made at the contract unit price for Crushed Stone Backfill which shall be full compensation for the item complete in place.

#### **4. SELECT BACKFILL**

- 4.1 Where directed by the Engineer, the Contractor shall backfill streets with select backfill. The select backfill shall be from a source as approved by the Engineer, and will be paid for on a cubic yard basis, truck measure. The backfill shall be placed in maximum 6" loose lifts and shall be compacted by an approved method of tamping to 95% of AASHTO T-99 Specification for the Standard Proctor Density Test. The Contractor shall provide any necessary equipment required to properly compact the ditch lines and this compaction work shall be accomplished in accordance with all applicable OSHA requirements.
- 4.2 Select backfill shall be a free-draining local material suitable for use as foundation or backfill for drainage structures. The Contractor shall uniformly deposit the material across the full width of the excavation in layers not to exceed six (6) inches in thickness and shall compact each layer as directed by the Engineer. Select backfill shall replace existing material that is unsuitable to serve as structure foundation. The volume of select backfill shall be measured based upon the truck loads of material ordered by the Engineer. Payment for the material shall be made at the contract unit price bid for Select Backfill and shall be full compensation for the item complete in place, including disposal of unsuitable material.

#### **5. BORROW EXCAVATION**

- 5.1 Where directed by the Engineer, the Contractor shall backfill the existing ditches with Borrow Excavation. The Borrow Excavation shall be from a source as approved by the Engineer, but shall at a minimum meet the requirements of Section 210 of the ALDOTSSHC, and will be paid for on a cubic yard basis, truck measure. The backfill shall be placed in maximum 10" loose lifts and shall be compacted by an approved method of tamping to 90% of AASHTO T-99 Specification for the Standard Proctor Density Test. The volume of select borrow shall be measured based upon the truck loads of material ordered by the Engineer. Payment for the material shall be made at the contract unit price bid for Borrow Excavation, truck bed measure, and shall be full compensation for the item complete in place, including disposal of unsuitable material.

#### **6. DITCH SHAPING AND REGRADING**

- 6.1 The Contractor shall also perform Ditch Shaping and Regrading in the areas specified in the Plans. This Ditch Grading shall include regrading and shaping the existing ditch channel and side slopes to a more uniform profile in preparation for placing stone rip rap.

- 6.2 Payment for grading the ditch in each work section will be made at the unit price bid per linear foot for Ditch Shaping and Regrading in the Proposal and shall be full compensation for all equipment, tools, labor and other incidentals necessary to complete the work as specified herein.
- 6.3 This pay item shall also include removing gravel and debris from the existing ditch channel. The pay item shall include all work required to remove and properly dispose of the material removed from the ditch.

## **7. ROADWAY STONE**

- 7.1 The item in the Proposal for Roadway Stone shall be utilized in these locations as directed by the Engineer and required to provide a satisfactory roadway surface along the ditch lines until such time as the ditch lines can be patched. It is anticipated that this stone will have a depth of 2-3". Roadway Stone shall meet requirements of Section 825 of the ALDOTSSHC, Latest Edition. The Crushed Aggregate Base Material shall be Type B.
- 7.2 The price bid shall include all costs of providing the material, spreading, and maintaining the surface until the streets and driveways are patched. Payment for Roadway Stone will be based upon the quantity of material used, measured in tons.

## **8. CONCRETE**

- 8.1 The concrete supplied for this work shall be composed of Portland Cement, fine aggregate, coarse aggregate, water, and admixtures, properly proportioned and mixed in accordance with the requirements of ASTM C 94, Ready Mixed Concrete, and as herein provided. All concrete supplied for the building shall have a 3,000 psi compressive strength. Maximum aggregate size shall be 1 1/2".
- 8.2 The cement shall be Type I of a standard brand which complies with ASTM Specification C 150. Cement utilizing fly ash which meets ASTM C 618 and any other applicable ASTM Specifications may be utilized in accordance with ASTM Specification C 150. Aggregates shall conform to ASTM Specification C 33. Potable water shall be utilized. An air entraining admixture meeting ASTM Specification C 260 shall be used to produce a total average air content which complies with the recommendations of ASTM C-94. The air content shall be 4.5% for 1 1/2" aggregate, with an allowable variation of plus or minus 1.0%. Water reducing admixture complying with ASTM Designation C 494 shall be used, and the use shall be in accordance with the manufacturer's recommendations.

- 8.3 Proportioning of concrete materials in each mix shall be based on maximum water cement ratio and minimum allowable strength in accordance with ACI Standard 613. Prior to placing any concrete on the job, a design mix will be prepared by a commercial testing laboratory for each mix. As a part of the preparation of these design mixes, cylinders will be prepared and tested. The design mixes and testing results will be submitted for approval. The maximum water content in gallons per bag of cement shall not exceed 6.50 gallons.
- 8.4 The consistency of the concrete shall be that required for the specific placing conditions and method of placement. The concrete shall be of such consistency that it can be worked readily into all corners and around reinforcing without segregation of materials or having free water collect on the surface. The concrete slump shall generally be in the range from 3 5 inches, but compliance with these slump requirements shall not necessarily designate a satisfactory mix. The Owner may require changes in proportions at any time as necessary to obtain a mix having satisfactory properties. Slump tests will be made by the Owner in accordance with ASTM Designation C 143.
- 8.5 The concrete shall be placed in accordance with ACI 614 and ACI 318. Buckets, chutes, and tremies shall be utilized to prevent the free fall of concrete during deposition. All concrete shall be thoroughly consolidated by the use of mechanical vibratory equipment, and this equipment will be utilized to work the concrete around the reinforcement and inserts to prevent the formation of voids. Vibrators shall not be used to move the concrete horizontally.
- 8.6 The concrete formwork shall be constructed such that the final structure conforms to the shapes, lines, and dimensions of the members as required by the plans and specifications. The forms shall be substantial and sufficiently tight to prevent the leakage of mortar. The forms shall be properly braced and/or tied to maintain their position and shape. Formwork shall conform to ACI Standards 318 and ACI Standards 347. All exposed surfaces shall be formed to produce a tolerance of a plus or minus 1/8" in the finished surfaces.
- 8.7 The locations of construction joints, expansion joints, and joint details shall be as shown on the plans or as approved by the Owner. All construction joints shall be provided with a keyway. Prior to placing plastic concrete against a concrete joint surface which has set, the surface shall be thoroughly cleaned of all loose material, laitance, dirt and other foreign material. The surface shall be watered until saturated and shall be kept wet until the fresh concrete is placed. Expansion joints shall be constructed in accordance with the detail shown on the Plans.

- 8.8 All exposed edges of concrete shall be provided with a minimum 1/2" chamfer. The concrete surfaces which will be exposed after backfilling shall be formed with prefabricated plywood or metal forms to provide a smooth even appearance. Upon removal of the forms, all tie holes, minor depressions, and rough surfaces shall be rubbed with a carborundum stone to remove form marks and to provide a smooth even finished surface. Any major honeycombs or joints which appear to be defective to the Engineer shall be cut out, a 2 inch keyway formed, and the defective area filled with an epoxy grout mix developing a compressive strength of at least 6800 psi in 28 days. The grout mix shall be "Masterbuilders Masterflow 713" or equal, and shall be placed in strict accordance with the recommendations of the manufacturer.
- 8.9 The concrete surfaces shall be finished in accordance with ACI 302. The exterior footing shall have a steel trowel finish and the interior footings shall have a wood float finish.
- 8.10 Concrete shall be cured in accordance with ACI 308. Proper curing shall be accomplished to insure that the concrete develops the proper design strength and to prevent surface cracks due to rapid water loss while the concrete is plastic. If curing compounds are utilized, they shall comply with ASTM C 309 and ASTM C 171.
- 8.11 Concrete reinforcement shall consist of deformed steel reinforcing bars conforming to ACI 318 and having yield strength of 60,000 psi. Details of reinforcing including hooks, splices, etc., and the placement of reinforcement shall conform to ACI 318. Reinforcing steel shall be accurately placed and properly supported in accordance with the Concrete Reinforcing Steel Institute Manual of Standard Practice. A complete submittal on the reinforcing shall be provided to the Owner for approval prior to fabricating any of the steel.
- 8.12 The cost of all concrete testing shall be paid for by the Owner, except for those tests in connection with the mix design and trial batches and as noted below. During the progress of the work, the Owner will cast test cylinders of the number he desires for testing to maintain a check on the compressive strength of the concrete actually being placed. The cost of all materials and field labor as required by the Owner in making test specimens shall be included in the contract price. Moisture tests of both fine and coarse aggregate shall be made by the Contractor at sufficient intervals to provide for accurate batching and proportioning. Testing equipment including wheelbarrow or buggy, shovel, slump cone and rod, plywood platform 30" square, twelve steel cover plates (7" x 7" x 1/8"), and hand trowel shall be furnished by the Contractor and made available at a location convenient to the work before commencing any concreting operation. All testing equipment shall be maintained in a clean condition by the Contractor. In the event of unsatisfactory test results in the compressive strength of the concrete, the

Contractor will be required to perform sufficient in place testing to determine the concrete strength, and the cost of this testing shall be borne by the Contractor.

**9. FIBERMESH**

9.1 Concrete engineered reinforcing fibers shall be used in all proposed storm drainage inlets, curb, aprons, flumes, and minor structure concrete items.

9.2 The reinforcing fibers shall be applied at a rate of 1.5 pounds per cubic yard and shall consist of 100% virgin polypropylene, collated, fibrillated fibers from the Fibermesh Co., or approved equal. Only fibrillated fibers designed and manufactured specifically for use in concrete from 100% virgin polypropylene and so certified by the manufacturer shall be acceptable.

9.3 Payment for this item shall be included in the contract unit prices bid for the items requiring fibermesh reinforced concrete.

**10. TRENCH COMPACTION**

10.1 The Contractor shall have on the job site at all times compaction equipment to use in trench compaction. The equipment shall be equal to a hand operated (walk behind) vibratory sheep's foot roller. This equipment shall be used in all pipe ditches located on street, road, or highway right-of-way to the extent allowed by OSHA. In the event that the compaction equipment provided will not achieve the specified compaction, the Contractor shall promptly provide equipment that will achieve the specified compaction results.

END OF SECTION

**GENERAL SPECIFICATIONS  
FOR  
EXCAVATION BACKFILL AND COMPACTION FOR UTILITIES**

**1. GENERAL**

**1.01 SECTION INCLUDES**

- A. Trench excavation, backfill, and compaction shall include, but not necessarily be limited to, the excavation, backfill, and compaction of trenches for utilities, as shown on the Drawings, and in accordance with the ENGINEER Standard Specifications and Details.

**1.02 DEFINITIONS**

- A. Pipe Foundation: Suitable and stable native soils that are exposed at trench subgrade after excavation to depth of bottom of bedding as shown on Drawings, or foundation backfill material placed and compacted in over-excavations.
- B. Embedment Material/Pipe Bedding: Portion of trench backfill that extends vertically from top of foundation up to level line at bottom of pipe, and horizontally from one trench sidewall to opposite sidewall.
- C. Haunching: Material placed on either side of pipe from top of bedding up to springline of pipe and horizontally from one trench sidewall to opposite sidewall.
- D. Initial Backfill: Portion of trench backfill that extends vertically from springline of pipe (top of haunching) up to level line 12-inches above top of pipe, and horizontally from one trench sidewall to opposite sidewall.
- E. Pipe Embedment Zone: Portion of trench backfill that consists of bedding, haunching and initial backfill.
- F. Trench Zone: Portion of trench backfill that extends vertically from top of pipe embedment up to pavement subgrade or up to final grade when not beneath pavement.
- G. Unsuitable Material: Unsuitable soil materials are the following:
  - 1. Materials that are classified as ML, CL-ML, MH, PT, OH, and OL according to ASTM D2487.

2. Materials that cannot be compacted to required density due to gradation, plasticity, or moisture content.
  3. Materials that contain large clods, aggregates, stones greater than 4- inches in any dimension, debris, vegetation, waste or any other deleterious materials.
  4. Materials that are contaminated with hydrocarbons or other chemical contaminants.
- H. Suitable Material: Suitable soil materials are those meeting specification requirements. Materials mixed with lime, fly ash, or cement that can be compacted to required density and meeting requirements for suitable materials may be considered suitable materials, unless otherwise indicated.
- I. Backfill: Suitable material meeting specified quality requirements placed and compacted under controlled conditions.
- J. Ground Water Control Systems: Installations external to trench, such as well points, eductors, or deep wells. Ground water control includes dewatering to lower ground water, intercepting seepage which would otherwise emerge from side or bottom of trench excavation, and depressurization to prevent failure or heaving of excavation bottom.
- K. Surface Water Control: Diversion and drainage of surface water runoff and rain water away from trench excavation. Rain water and surface water accidentally entering trench shall be controlled and removed as part of excavation drainage.
- L. Excavation Drainage: Removal of surface and seepage water in trench by sump pumping and using drainage layer, as defined in ASTM D2321, placed on foundation beneath pipe bedding or thickened bedding layer of Class I material.
- M. Trench Conditions are defined with regard to stability of trench bottom and trench walls of pipe embedment zone. Maintain trench conditions that provide for effective placement and compaction of embedment material directly on or against undisturbed soils or foundation backfill, except where structural trench support is necessary.
1. Dry Stable Trench: Stable and substantially dry trench conditions exist in pipe embedment zone as result of typically dry soils or achieved by ground water control (dewatering or depressurization) for trenches extending below ground water level.



2. Stable Trench with Seepage: Stable trench in which ground water seepage is controlled by excavation drainage.
    - a. Stable Trench with Seepage in Clayey Soils: Excavation drainage is provided in lieu of or to supplement ground water control systems to control seepage and provide stable trench subgrade in predominately clayey soils prior to bedding placement.
    - b. Stable Wet Trench in Sandy Soils: Excavation drainage is provided in embedment zone in combination with ground water control in predominately sandy or silty soils.
  3. Unstable Trench: Unstable trench conditions exist in pipe embedment zone if ground water inflow or high water content causes soil disturbances, such as sloughing, sliding, boiling, heaving or loss of density.
- N. Sub-trench: Sub-trench is special case of benched excavation. Sub-trench excavation below trench shields or shoring installations may be used to allow placement and compaction of foundation or embedment materials directly against undisturbed soils. Depth of sub-trench depends upon trench stability and safety as determined by the Contractor.
- O. Trench Dam: Placement of low permeability material in pipe embedment zone or foundation to prohibit ground water flow along trench.
- P. Over-excavation and Backfill: Excavation of subgrade soils with unsatisfactory bearing capacity or composed of otherwise unsuitable materials below top of foundation as shown on Drawings, and backfilled with foundation backfill material.
- Q. Foundation Backfill Materials: Natural soil or manufactured aggregate of controlled gradation, and geotextile filter fabrics as required, to control drainage and material separation. Foundation backfill material is placed and compacted as backfill to provide stable support for bedding. Foundation backfill materials may include concrete seal slabs.
- R. Trench Safety Systems: Includes both protective systems and shoring systems.
- S. Trench Shield (Trench Box): Portable worker safety structure moved along trench as work proceeds, used as protective system and designed to withstand forces imposed on it by cave in, thereby protecting persons within trench. Trench shields may be stacked if so designed or placed in series depending on depth and length of excavation to be protected.

- T. Shoring System: Structure that supports sides of an excavation to maintain stable soil conditions and prevent cave-ins, or to prevent movement of ground affecting adjacent installations or improvements.

#### 1.03 SCHEDULING

- A. Schedule work so that pipe embedment can be completed on same day that acceptable foundation has been achieved for each section of pipe installation, manhole, or other structures.
- B. The Contractor shall not excavate more trench in any day than can be completed (facility installed and trench backfilled) in the same day, unless by written permission of ENGINEER. ENGINEER shall be empowered at any time to require the backfilling of open trenches over completed pipe lines if, in their judgment, such action is necessary.

#### 1.04 SUBMITTALS

- A. Conform to requirements of Submittal Procedures.
- B. Submit planned typical method of excavation, backfill placement and compaction including:
  - 1. Trench widths
  - 2. Procedures for foundation and pipe zone bedding placement, and trench backfill compaction.
  - 3. Procedures for assuring compaction against undisturbed soil when pre-manufactured trench safety systems are proposed.
- C. Submit backfill material sources and product quality information in accordance with requirements of Section — Utility Backfill Materials.
- D. Submit trench excavation safety program. Identify by name who will be OSHA competent person for excavations. If special shoring system is to be used, include designs for special shoring meeting requirements defined in Paragraph 1.06, Special Shoring Design Requirements contained herein.
- E. Submit record of location of utilities as installed, referenced to survey control points. Include locations of utilities encountered or rerouted. Give stations, horizontal dimensions, elevations, inverts, and gradients.

## 1.05 TESTS

- A. Geotechnical testing and analysis of backfill materials for soil classification and compaction testing during construction shall be provided by the Contractor and performed by an independent, State-certified, testing company approved by ENGINEER. The results of all failing tests shall be communicated to ENGINEER immediately. Written results of all tests performed, shall be presented to ENGINEER in a timely manner.
- B. Perform backfill material source qualification testing in accordance with requirements of Section — Utility Backfill Materials.
- C. The Contractor will arrange for all in-place moisture/density testing on the project.
- D. Frequency:

Compaction testing shall be performed on random lifts a minimum of every 300 LF unpaved areas and 100 LF in paved areas unless otherwise approved by the ENGINEER. ENGINEER reserves the right to require re-tests if the initial compaction test fails.

1. If ground water is present, at the discretion of the ENGINEER, compaction testing shall be increased to every 100 LF in unpaved areas.
2. A minimum of one (1) compaction test per lift shall be performed for all backfill operations with less linear footage than specified in 1.05 D.
3. The testing agency shall determine at the time of testing the location of each compaction test within the specified testing length.
4. As an alternative to the compaction testing frequency specified, the Contract shall have the option to demonstrate acceptable compaction at the start of the project.
  - a. At the start of the trenching operation, the Contractor shall demonstrate to the ENGINEER representative through the results reported by the accepted testing agency that the compaction density specified can be attained by the compaction equipment and methods the Contractor intends to use.
  - b. Once the method and equipment has been approved, no substitutions will be permitted without ENGINEER's approval.

- c. Additional demonstration of the suitability of the compaction equipment and methods will be required whenever there is a significant change in material characteristics or change in compaction equipment or method.
- d. Should testing determine that the required density is not being met, or the material is outside the specified moisture range, the Contractor shall, without additional compensation, reexcavate, rework, and/or recompact the particular layer or section until the required density and/or moisture is attained.

E. Compaction

- 1. The Contractor shall, in unimproved areas outside the public rights-of-way, compact each trench backfill layer in such a manner as to obtain a dense backfill free of voids and not susceptible to undue settlement or depression. Trench backfill extending to not less than 1-foot in depth above the top of pipe shall be compacted to at least 90% of maximum density at a moisture content within 5% of the optimum in accordance with ASTM D1556.
- 2. Trench backfill within all rights-of-way of improved or paved areas shall be compacted to at least 95% of maximum density at a moisture content within 5%, or local requirements which ever is more stringent, of the optimum moisture in accordance with ASTM D1556. The final 1-foot of trench backfill to pavement subgrade shall be compacted to at least 95% of maximum density at a moisture content within 5% of the optimum in accordance with ASTM D1556.

1.06 SPECIAL SHORING DESIGN REQUIREMENTS

- A. Have special shoring designed or selected by Contractor's Professional Engineer registered in the State the project is being completed to provide support for sides of excavations, including soils and hydrostatic ground water pressures as applicable, and to prevent ground movements affecting adjacent installations or improvements such as structures, pavements and utilities. Special shoring may be a premanufactured system selected by Contractor's Professional Engineer to meet project site requirements based on manufacturer's standard design.
- B. The requirement for special shoring shall be determined by ENGINEER for all excavations within 10-feet of an ENGINEER owned asset.

## **2. PRODUCTS**

### **2.01 EQUIPMENT**

- A. Perform excavation with hydraulic excavator or other equipment suitable for achieving requirements of this Section.
- B. Heavy compaction equipment shall not be used until adequate cover is attained in order to prevent damage to pipes, conduits, or ducts.
- C. Use trench shields or other protective systems or shoring systems, including special shoring systems as referenced in Paragraph 1.06, which are designed and operated in accordance with all Local, State, and Federal (including OSHA) standards and regulations.

### **2.02 MATERIAL CLASSIFICATIONS**

- A. Embedment and Trench Zone Backfill Materials: Conform to classifications and product descriptions of Section – Utility Backfill Materials.
- B. Concrete Encasement: Concrete used for encasement or caps shall have a minimum compressive strength of 3,000 psi.
- C. Concrete Backfill: Also known as flowable fill. Flowable fill must be “excavatable” as defined by the National Ready Mixed Association as having a compressive strength not exceeding 150 psi.
- D. Concrete for Trench Dams: Concrete backfill or 3 sack premixed (bag) concrete.

## **3. EXECUTION**

### **3.01 STANDARD PRACTICE**

- A. Install flexible pipe, including "semi-rigid" pipe, to conform to standard practice described in ASTM D2321, and as described in this Section. Where an apparent conflict occurs between standard practice and requirements of this Section, this Section governs.
- B. Install rigid pipe to conform to standard practice described in ASTM C12, and as described in this Section. Where an apparent conflict occurs between standard practice and requirements of this Section, this Section governs.

### 3.02 PREPARATION

- A. Maintain barricades and warning lights for streets and intersections affected by Work, and that are considered hazardous to traffic movements as specified in the approved traffic control plan for the project.
- B. It is the Contractor's responsibility to obtain all required permits for excavation to include a Traffic Control Plan approved by the local governing authority.
- C. Perform work to conform to applicable safety standards and regulations, as outlined in current OSHA, State and local regulations.
- D. Immediately notify agency or company owning any existing utility line which is damaged, broken, or disturbed. Obtain approval from ENGINEER and agency for any repairs or relocations, either temporary or permanent.
- E. Remove existing pavements and structures, including sidewalks and driveways, to conform to local (local, State DOT, DPW, etc.) requirements.
- F. Install and operate necessary dewatering and surface-water control measures. Provide stable trench to allow installation in accordance with Specifications.
- G. Maintain permanent benchmarks, monuments, and other reference points. Unless otherwise directed in writing, at the expense of the Contractor a Licensed Surveyor shall replace those which are damaged or destroyed in accordance with the requirements of the ENGINEER and local or State requirements.

### 3.03 CRITICAL LOCATION INVESTIGATION

- A. Horizontal and vertical location of various underground lines shown on Drawings, including but not limited to water lines, gas lines, storm sewers, sanitary sewers, telecommunication lines, electric lines or power ducts, pipelines, concrete and debris, are based on best information available but are only approximate locations.
- B. The Contractor is responsible for coordinating all utility locates within the Limits of Disturbance per the standard procedures for the project location (One call system, DPW, Utility Company Coordination, etc.)
- C. The Contractor is responsible for verifying the location of existing utilities in manner that complies with all local, State and Federal regulations. Use extreme caution and care when uncovering these lines.

- D. Notify ENGINEER in writing immediately upon identification of obstruction.
- E. Notify involved utility companies of date and time that investigation excavation will occur and request that their respective utility lines be marked in field. Comply with utility or pipeline company requirements that their representative be present during excavation. Provide ENGINEER written 48 hours notice prior to field excavation or related work.

#### 3.04 PROTECTION

- A. Protect trees, shrubs, lawns, existing structures, and other permanent objects outside of grading limits and within grading limits as designated on Drawings.
- B. Protect and support above-grade and below-grade utilities which are to remain.
- C. Restore damaged permanent facilities to a condition equal to or better than pre-construction conditions unless replacement or abandonment of facilities is indicated on Drawings.
- D. Take measures to minimize erosion of trenches. Do not allow water to pond in trenches. Where slides, washouts, settlements, or areas with loss of density or pavement failures or potholes occur, repair, recompact, and pave those areas at no additional cost to ENGINEER.
- E. Protection of Property and Structures: The Contractor shall be responsible for all damage and assume all expense for direct or indirect injury caused by his work, to above ground facilities or below ground facilities shown on the Drawings. The Contractor shall, at his own expense, sustain in place and protect from direct or indirect injury all existing facilities in the vicinity of the excavation, whether above or below the ground, or that may appear in the trench. The Contractor shall be responsible for the implementation of protective measures associated with the presence or proximity of pipes, poles, tracks, walls, buildings, property markers, and other structures and property of every kind and description in or over his trenches or in the vicinity of his work whether above or below the surface of the ground.

#### 3.05 EXCAVATION

- A. Except as otherwise specified or shown on Drawings, install underground utilities in open cut trenches with vertical sides.
- B. Perform excavation work so that pipe, conduit, and ducts can be installed to depths and alignments shown on Drawings. Avoid disturbing surrounding ground and existing facilities and improvements.

- C. Trenches shall be wide enough to allow for compaction equipment.
- D. Use sufficient trench width or benches above embedment zone for installation of well point headers or manifolds and pumps where depth of trench makes it uneconomical or impractical to pump from surface elevation. Provide sufficient space between shoring cross braces to permit equipment operations and handling of forms, pipe, embedment and backfill, and other materials.
- E. Upon discovery of unknown utilities, badly deteriorated utilities not designated for removal, or concealed conditions notify ENGINEER immediately.
- F. Trench Support:
  - 1. The Contractor shall support the sides and ends of all excavations wherever necessary with braces, sheeting, shoring or stringers, trench boxes, or other acceptable excavation support systems. All timbering shall be installed by persons skilled in such work and shall be so arranged that it may be withdrawn as backfilling proceeds, without injury to the utility or structure constructed or to any roadbed or adjacent structure or property.
  - 2. All work shall be performed in accordance with the latest OSHA requirements.
  - 3. All timbering in excavations, trench boxes, or excavation support systems shall be withdrawn as the backfilling is being done, except where and to such extent as the ENGINEER shall order in writing that said timbering or excavation support system be left in place or where the ENGINEER permits the trench support to be left in place at the Contractor's expense and upon his request. The Contractor shall cut off any sheeting left in place 2 feet below finished grade and shall remove the material cut off without compensation therefore.
  - 4. The support of the trench shall be the sole responsibility of the Contractor.
  - 5. Removal or Moving of trench shoring shall be performed so that pipe, and backfill materials, after placement and compaction, are not damaged nor disturbed, nor degree of compaction reduced. Re-compact after shoring is moved if soil is disturbed.
  - 6. The Contractor shall coordinate and provide safe access at all times to all inspecting and testing activities for ENGINEER and ENGINEER-authorized representatives.



### 3.06 HANDLING EXCAVATED MATERIALS

- A. Use only excavated materials, which are suitable as defined in this Section and conforming to Section — Utility Backfill Materials. Place material suitable for backfilling in stockpiles per the most current OSHA standards.
- B. When required, provide additional backfill material conforming to requirements of Section Utility Backfill Materials.
- C. Stockpile locations shall be pre-approved by the ENGINEER and the local governing authority.
- D. All excavated material not used as backfill the same day as excavated shall be removed from the site and/or stockpiled in an area pre-approved by the ENGINEER.

### 3.07 TRENCH FOUNDATION

- A. The Contractor shall, before any pipe or appurtenance is installed, fill all unauthorized depressions or irregularities in the bottom of the trench or tunnel with firmly compacted embankment or other approved material.
- B. It shall be the Contractor's responsibility to adequately control water that may be present in the excavation. He shall provide for the disposal of water removed from excavations in such a manner not to cause damage to public or private property or to any portion of the Work completed or in progress or cause any impediment to the use of any area by the public. Nor shall the Contractor discharge any flushing or ground water or any material of any nature into existing sanitary sewer system during construction of the facilities. All water shall be discharged through an approved sediment control device.
- C. Notify ENGINEER immediately when unsatisfactory material is encountered on trench bottom. With ENGINEER approval, up to 12 -inches of additional undercut may be permitted to achieve suitable trench bottom. If the additional undercut does not result in a satisfactory trench bottom, the Contractor shall obtain a bedding design prepared by a Geotechnical Engineer licensed in the State in which the project is being constructed.
- D. Perform over excavation, if directed by ENGINEER, in accordance with Paragraph 3.07.C above. Removal of material maybe required. Even though Contractor has not determined material to be unsuitable.
- E. Trench dams shall be installed as determined by the ENGINEER when ground water is encountered.

3.08 PIPE EMBEDMENT, PLACEMENT, AND COMPACTION

- A. The following material shall be used for the pipe embedment zone (bedding, haunching, and initial backfill) based on project location.

Location	Water Main & Sanitary Force Main			Gravity Sewer
	DIP	PVC	HDPE	
Alabama	Native Material	Native Material	Native Material	Native Material

- B. Remove loose, sloughing, caving, or otherwise unsuitable soil from bottoms and sidewalls of trenches immediately prior to placement of embedment materials.
- C. Place embedment including bedding, haunching, and initial backfill as shown on Drawings.
- D. For pipe installation, manually spread embedment materials around pipe to provide uniform bearing and side support when compacted. Protect flexible pipe from damage during placing of pipe zone bedding material. Perform placement and compaction directly against undisturbed soils in trench sidewalls, or against sheeting which is to remain in place.
- E. Do not place trench shields or shoring within height of embedment zone unless means to maintain density of compacted embedment material are used. If moveable supports are used in embedment zone, lift supports incrementally to allow placement and compaction of material against undisturbed soil.
- F. Place geotextile to prevent particle migration from in-situ soil into open-graded (Class I) embedment materials or drainage layers.
- G. Do not damage coatings or wrappings of pipes during backfilling and compacting operations. When embedding coated or wrapped pipes, do not use crushed stone or other sharp, angular aggregates.
- H. Place haunching material around pipe and compact per the pipe manufacture’s recommendation to provide uniform bearing and side support. The haunching shall be installed in a manner that prevents the pipe from moving.

- I. Place electrical conduit, if used, directly on foundation without bedding.
- J. The method of compaction of the embedment zone material shall comply with the pipe manufacture's recommendation. Water tamping is not allowed.

### 3.09 TRENCH ZONE BACKFILL PLACEMENT AND COMPACTION

- A. Place backfill for pipe or conduits and restore surface as soon as practicable. Leave only minimum length of trench open as necessary for construction.
- B. For water and sewer lines under existing pavement, use an aggregate base backfill up to the pavement base or sub grade. Aggregate base shall meet the specifications of and be installed per the Department of Transportation regulations for the State in which the project is located.
- C. Unless otherwise shown on Drawings, for trench excavations not under pavement, random backfill of suitable material may be used in trench zone.
  - 1. Clay Soils may be used as trench zone backfill outside paved areas.
  - 2. Place in maximum 8-inch thick lift.
  - 3. Compact per Paragraph 1.05 of this specification section.
  - 4. Moisture content as necessary to achieve density.
- D. For electric conduits, remove form work used for construction of conduits before placing trench zone backfill.

### 3.10 MANHOLES, JUNCTION BOXES AND OTHER PIPELINE STRUCTURES

- A. Manholes, junction boxes and other pipeline structures shall have bedding consisting of a minimum of 1' compacted 3/4" to 1" clean stone. The compacted 3/4" to 1" stone shall be installed horizontally out from the base to the limits of the excavation (minimum 1'), and extend up to a minimum of 1' above the pipe or base, whichever is greater (does not include the upper connection of a drop inlet). The stone shall be installed to a uniform depth around the entire perimeter of the structure. The remainder of the backfill shall be installed per section 3.09 Trench Zone Backfill Placement and Compaction to include paved and unpaved area requirements.

3.11 DISPOSAL OF EXCESS MATERIAL

- A. Dispose of excess materials in accordance with requirements of the contract documents, State and local requirements.

END OF SECTION



# SOUTHERN

ENGINEERING SOLUTIONS

PERSONAL SERVICE...PROFESSIONAL SOLUTIONS

201 EAST TROY ST  
P.O. BOX 610  
ANDALUSIA, AL 36420

OFFICE 334.222.1849  
FAX 334.222.1869  
SOUTHERNENGINEERINGSOLUTIONS.COM

# STREET RESURFACING AND REPAIRS

## FY 2023 REBUILD ALABAMA ACT ANNUAL GRANT PROGRAM

### CITY OF JACKSON, ALABAMA JANUARY 2024

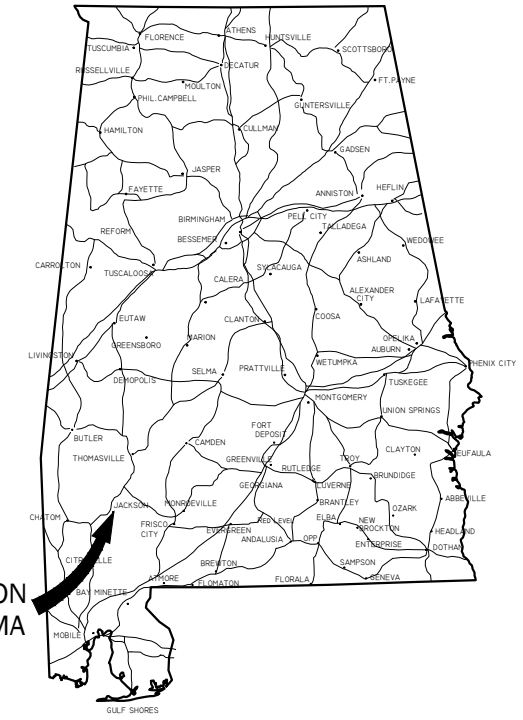

PROJECT LOCATION  
JACKSON, ALABAMA

**MAYOR**  
PAUL SOUTH

**CITY CLERK**  
RETA CORLEY

**CITY COUNCIL**  
KEDRICK BETTIS  
JANE JAMES  
AUDRA RAYBON  
JIMMY ATCHISON  
CAROL GOOLSBY  
DARON BOLEN



JANUARY 8, 2024

Drawing Index	
1	Title Sheet
2	Vicinity Map
3	Project Notes
4	Ochre Avenue Paving Layout
5	Stanley Drive Paving Layout
6-7	Stanley Drive Drainage
8	Odom Drive Paving Layout
9	Odom Drive/Shady Lane Paving Layout
10	MIDWAY STREET PAVING LAYOUT
11	East State Street Paving Layout
12	Wilson Court Paving Layout
13	Wilson Cout/McIntyre Avenue Paving Layout
14	Guy Street/Center Street Paving Layout
15	Middle Street Paving Layout
16	West Rose Street Paving Layout
17	West Rose Street/Industrial Road Paving Layout
18-19	Industrial Road Paving Layout
20	Griffin Street Paving Layout
21-26	Project Details
27	Erosion Control Plan
28-32	Traffic Control Plan



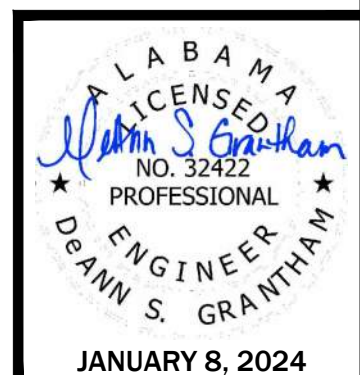
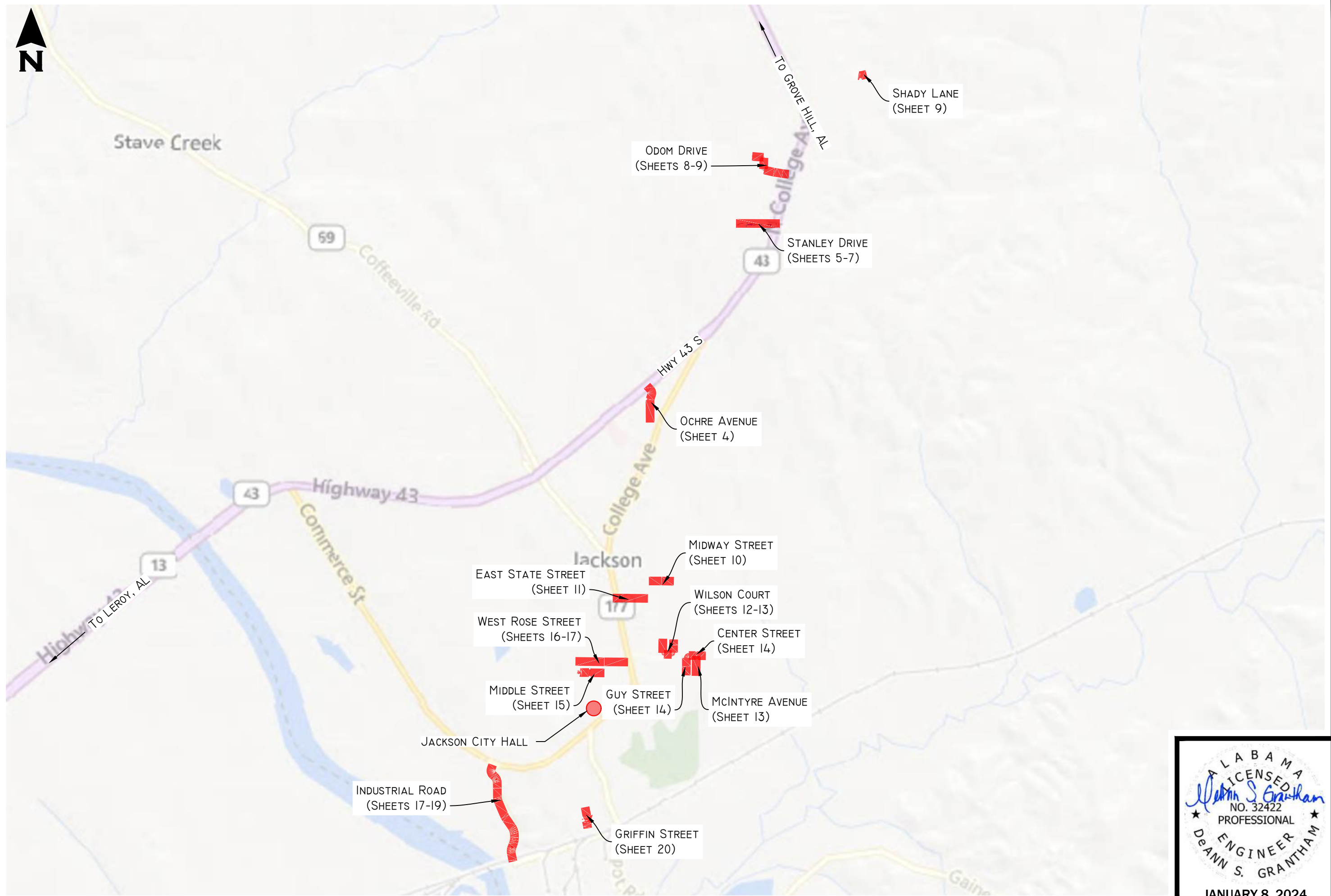

DESIGNED BY	DSG
DRAWN BY	JAC
DATE	JAN. 2024
CADD FILE	JACKSON RAA
PROJECT NO	2349101
REVISED	*
SHEET	2 OF 32

GENERAL NOTES

TRAFFIC CONTROL IN WORK AREAS

DURING CONSTRUCTION WORK ALONG STATE, COUNTY, AND CITY ROADS AND STREETS, THE CONTRACTOR SHALL COMPLY WITH THE APPLICABLE PROVISIONS OF PART VI OF THE FEDERAL MANUAL ON UNIFORM TRAFFIC CONTROL DEVICES, LATEST EDITION. THE ENGINEER, IN PERFORMANCE OF HIS DUTIES OUTLINED IN THESE SPECIFICATIONS DOES NOT GUARANTEE OR INSURE THE CONTRACTOR'S COMPLIANCE WITH THESE REGULATIONS.

EXISTING CONTROLS, UTILITIES AND UNDERGROUND OBSTRUCTIONS

DO NOT DISTURB SURVEY MARKERS. THE CONTRACTOR WILL BE RESPONSIBLE TO GIVE SUFFICIENT NOTIFICATION TO THE UTILITY OWNERS THAT CONSTRUCTION WILL TAKE PLACE WHEREBY THE UTILITY OWNER WILL BE AFFORDED AN OPPORTUNITY TO ADEQUATELY MARK ON THE GROUND OR WITH SUFFICIENT MAPS THE UTILITY LOCATIONS. COORDINATION OF SUCH INFORMATION AND UTILITY LOCATIONS SHALL BE THE SOLE RESPONSIBILITY OF THE CONTRACTOR.

EROSION CONTROL

PRIOR TO BEGINNING ANY CONSTRUCTION ACTIVITIES ON THIS PROJECT THE CONTRACTOR SHALL INCORPORATE APPROPRIATE BEST MANAGEMENT PRACTICES AT THE PROJECT SITE INCLUDING, BUT NOT LIMITED TO THE FOLLOWING:

- A. SEDIMENTATION AND EROSION CONTROL MEASURES SHOULD BE IN PLACE PRIOR TO AND DURING ANY CONSTRUCTION ACTIVITY.
- B. PERMANENT HERBACEOUS VEGETATION IN DISTURBED AREAS SHOULD BE ESTABLISHED WITHIN 13 DAYS OF GROUND DISTURBING ACTIVITIES TO PROVIDE LONG TERM EROSION CONTROL.
- C. EXCAVATED MATERIAL SHOULD BE STOCKPILED AWAY FROM STREAMS, DITCHES AND OTHER STORMWATER CONVEYING SYSTEMS.

SITE MAINTENANCE AND CLEAN-UP

THE WORK SITE SHALL BE CLEANED UP ON DAILY BASIS. PRIOR TO STOPPING WORK FOR THE DAY, THE DITCH LINES SHALL BE BACKFILLED AND TAMPED. THE CONTRACTOR SHALL BE RESPONSIBLE FOR THE DAILY MAINTENANCE OF ALL DITCH LINES AND STREET CROSSINGS ON PAVED STREETS. ROADS WILL BE REPAIRED WITH SURFACE AGGREGATE UNTIL THE PAVEMENT CAN BE REPLACED. THE CONTRACTOR WILL BE RESPONSIBLE FOR DRESSING UP ANY AREAS OF THE DITCH ON WHICH ANY SETTLEMENT OCCURS.

COMPACTION TESTING

COMPACTION TESTING SHALL BE PERFORMED BY THE ENGINEER.

SEEDING AND MULCHING

SEEDING AND MULCHING SHALL BE PERFORMED WITHIN 15 DAYS, OR AS APPROVED BY THE ENGINEER. THIS ITEM SHALL BE A SUBSIDIARY OBLIGATION TO VARIOUS ITEMS IN THE CONTRACT, AND SHALL INCLUDE TOPSOIL AS NEEDED. EXCESSIVE DISTURBANCE WILL NOT BE PAID FOR AND SHALL BE THE SOLE RESPONSIBILITY OF THE CONTRACTOR TO RESTORE.

TACK COAT/JOINT SEALANT

IN ALL AREAS WHERE TACK COAT AND JOINT SEALANT IS REQUIRED, IT SHALL BE A SUBSIDIARY COST OF PLANT MIX (PER TON). APPROXIMATE QTY: 1,225GAL (TACK COAT) AND 0.60MILE (JOINT SEALANT).

CLIPPING SHOULDERS

CONTRACTOR SHALL PROVIDE A CLEAN EDGE ALONG EXISTING PAVEMENT OR CURBING BY MEANS OF CLIPPING AND REMOVING OR ADDING SUITABLE TOPSOIL FILL MATERIAL AS DIRECTED BY ENGINEER/OWNER. THIS WORK/MATERIAL SHALL BE SUBSIDIARY TO THE PROJECT AS A WHOLE.

TREATMENT OF VEGETATION PRIOR TO APPLYING ASPHALT

CONTRACTOR SHALL APPLY PRIMITOL (OR EQUIVALENT HERBICIDE APPROVED BY THE ENGINEER) TO ANY AREAS THAT HAD GRASS/WEEDS BEFORE CLEANING/PREPARING SURFACES FOR RESURFACING (RATE 25 OZ OF SOLUTION PER 1000 S.F). COST SHALL BE A SUBSIDIARY OF PLANT MIX (PER TON).

DRIVEWAYS

EXISTING ASPHALT, DIRT, OR GRAVEL DRIVES SHALL RECEIVE A MINIMUM ONE FOOT APRON THAT MATCHES GRADE OF THE DRIVEWAY AND SHALL BE PLACED TO ENSURE NO WATER PONDS. IF EXISTING DRIVE IS CONCRETE, PROVIDE A SMOOTH TRANSITION FROM STREET TO DRIVE, BUT NO CONCRETE REMOVAL SHALL BE PERFORMED. THIS WORK WILL BE SUBSIDIARY TO OTHER PAVING PAY ITEMS.

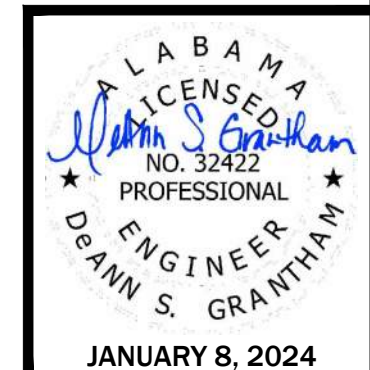

DESIGNED BY	DSG
DRAWN BY	JAC
DATE	JAN. 2024
CADD FILE	JACKSON RAA
PROJECT NO	2349101
REVISED	*
SHEET	3 OF 32

PROJECT NOTES  
 STREET RESURFACING & DRAINAGE REPAIRS  
 JACKSON, ALABAMA





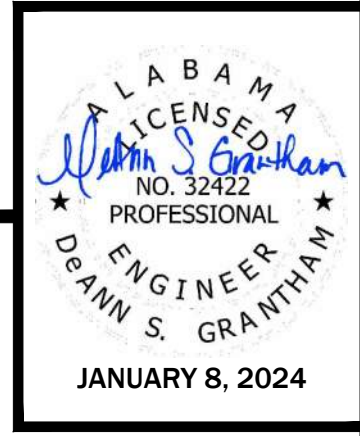
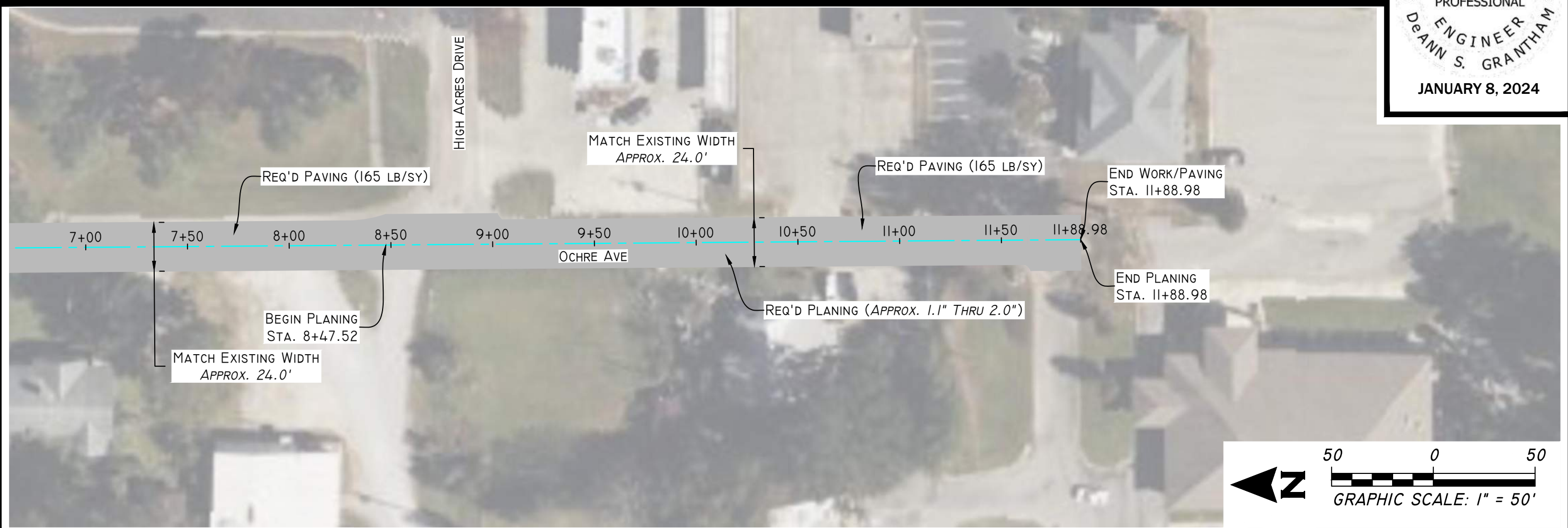
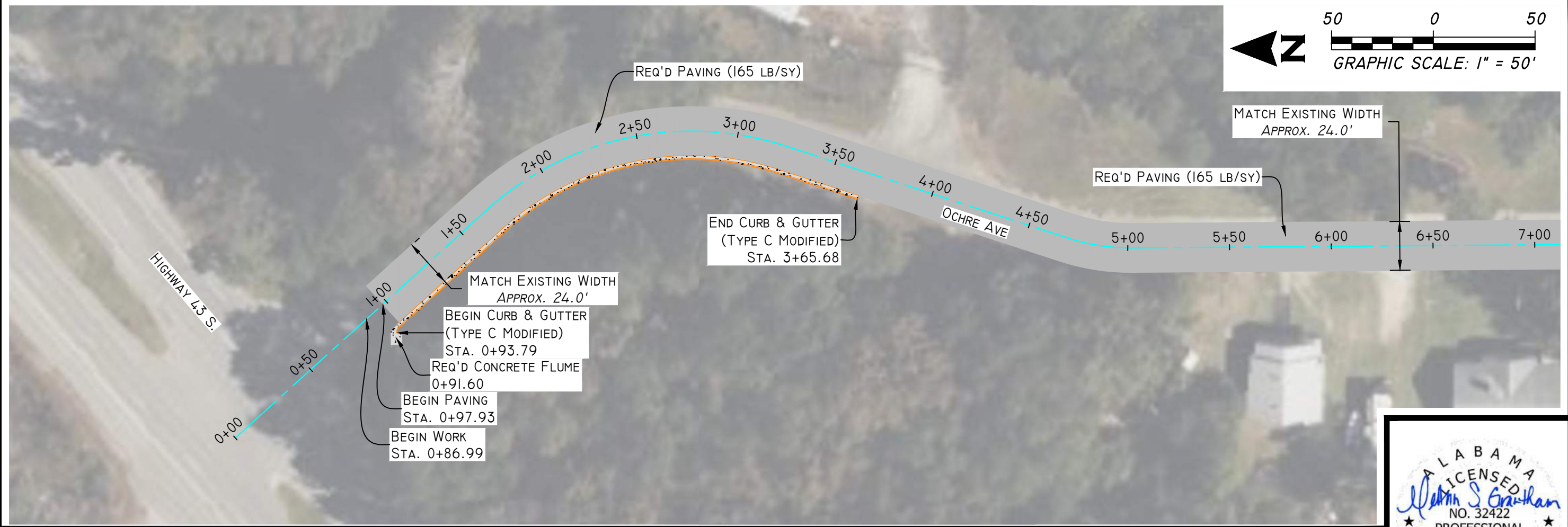

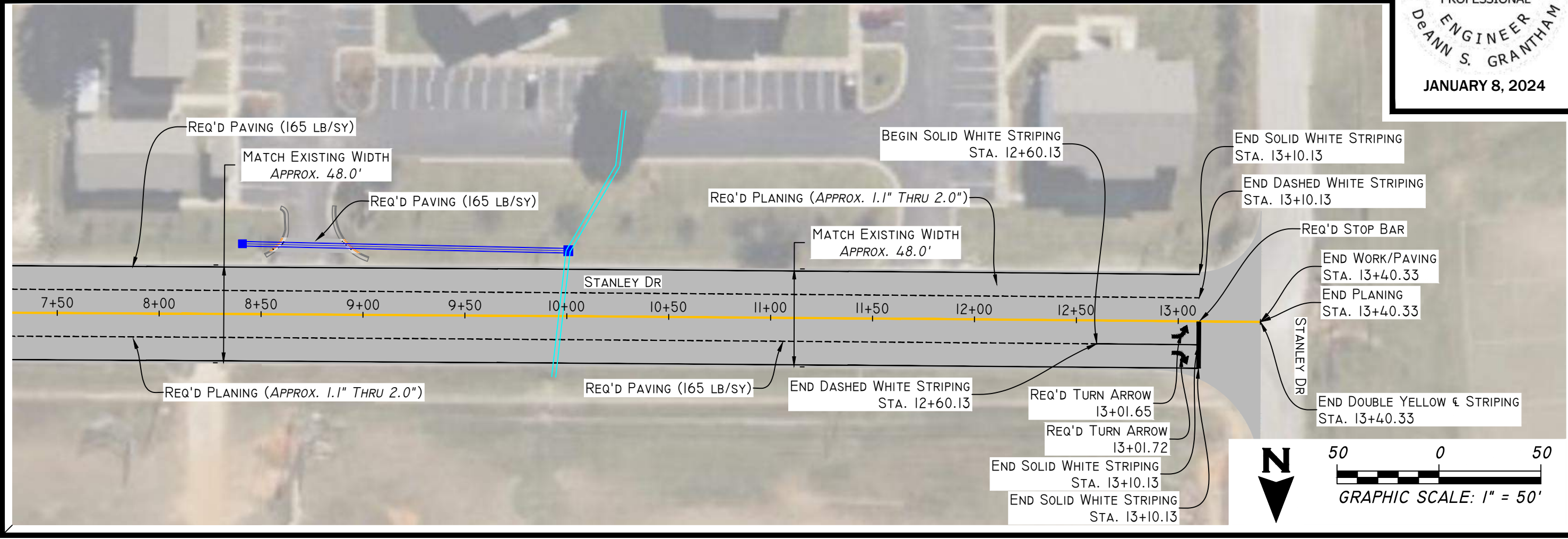
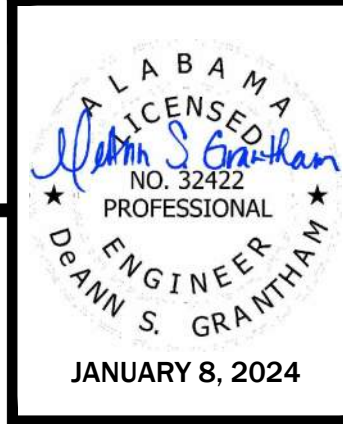
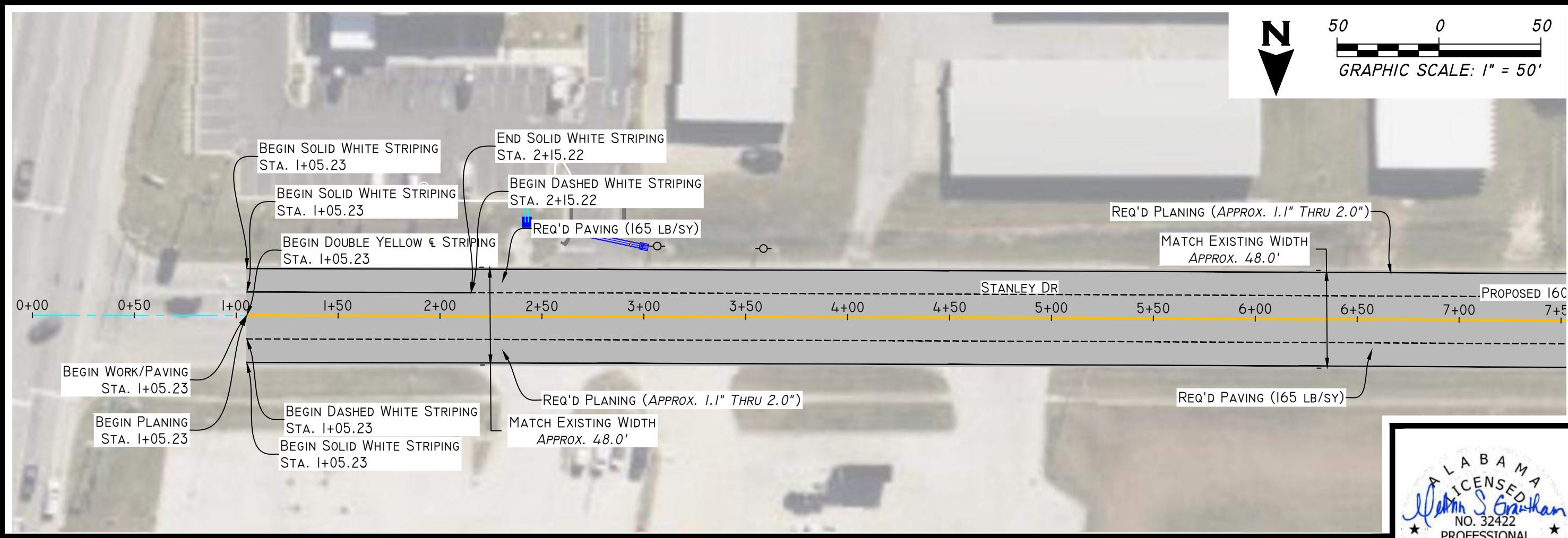

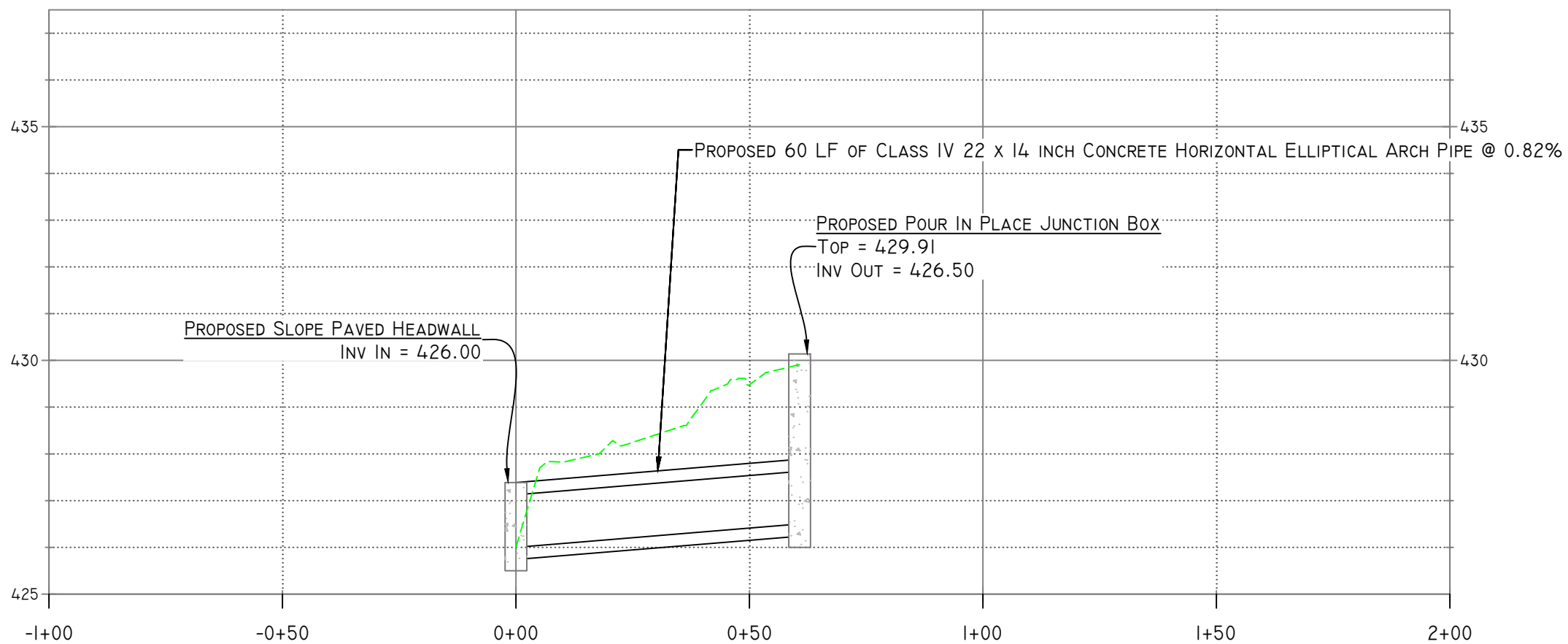
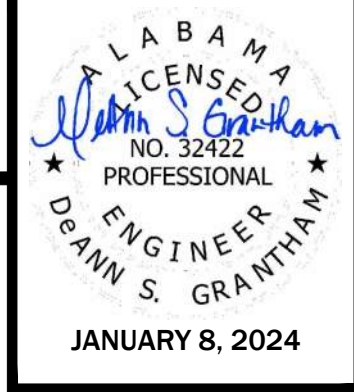
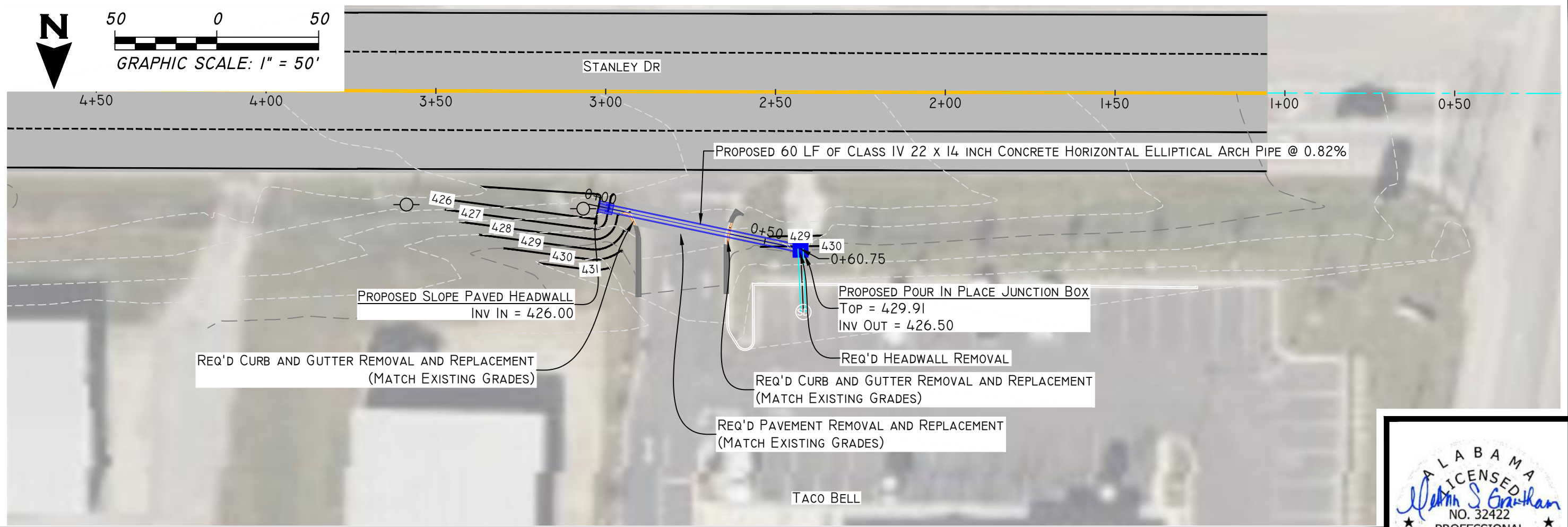

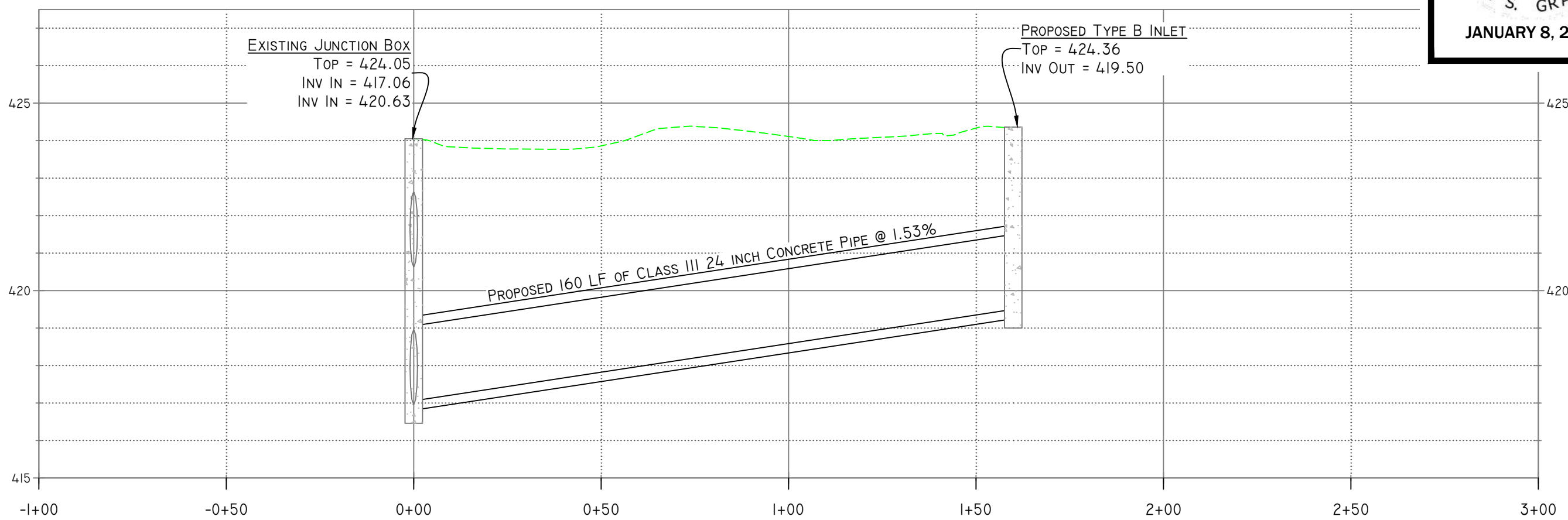
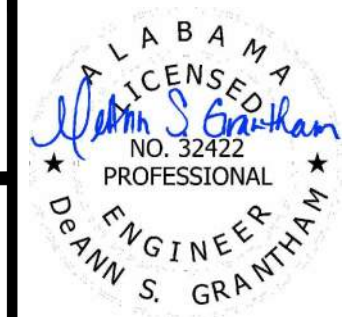
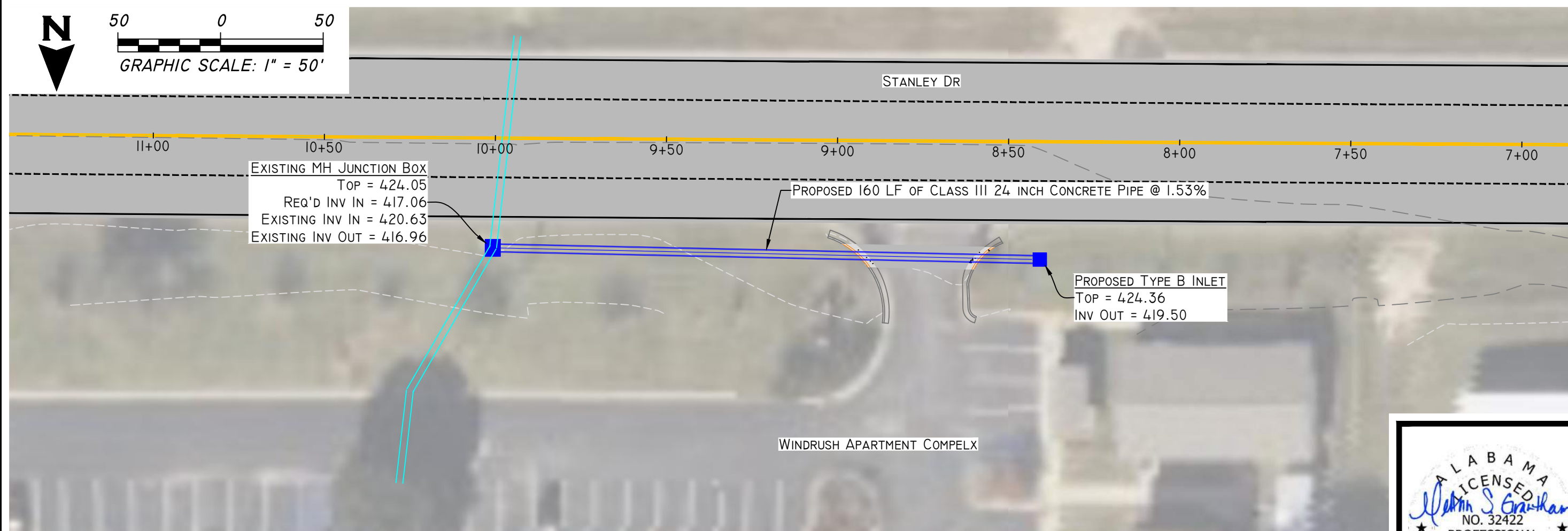
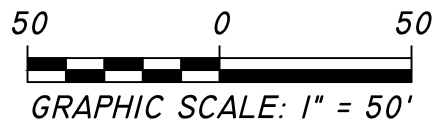

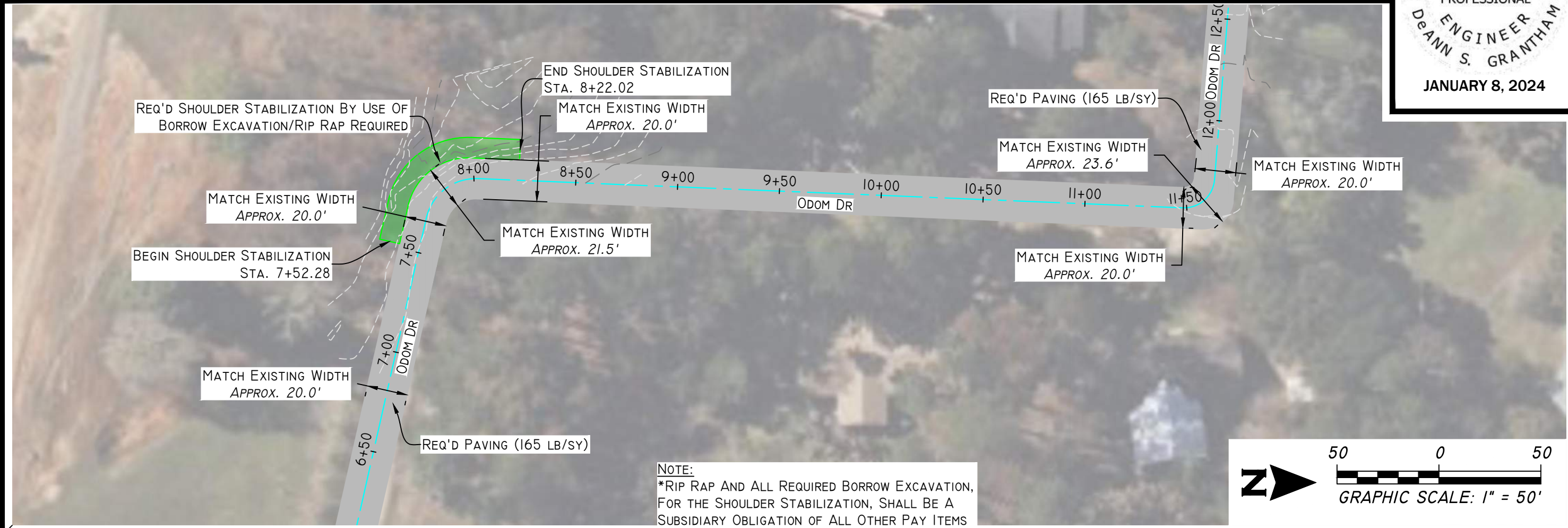
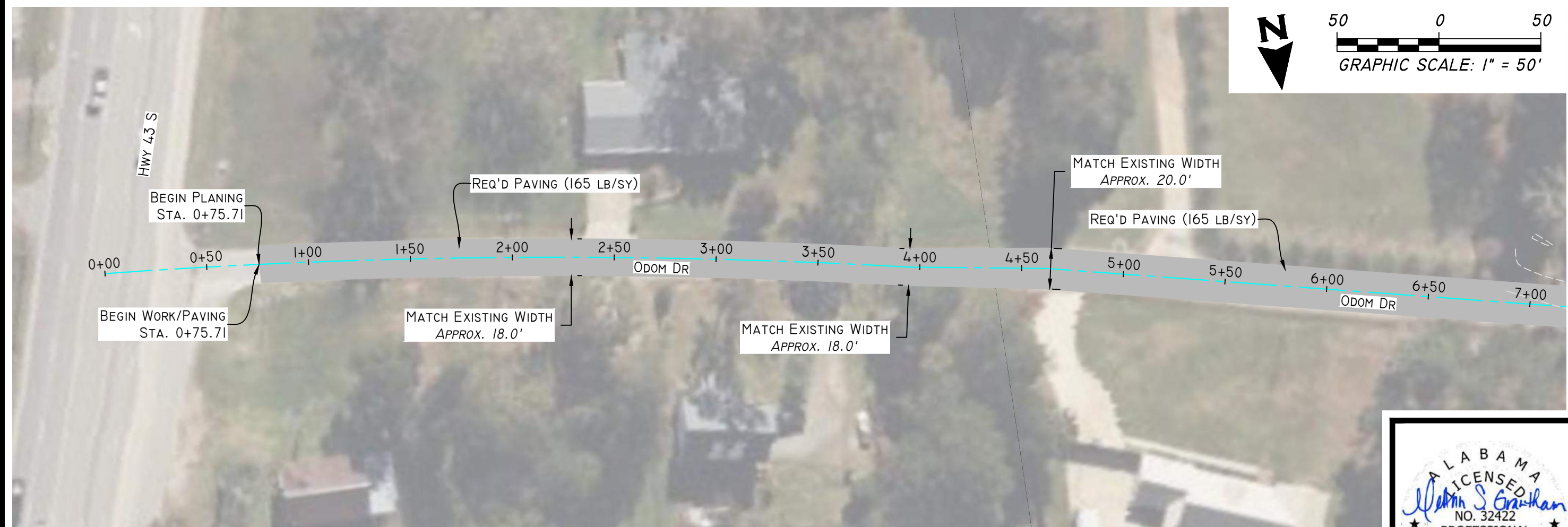

**NOTE:**  
 \*RIP RAP AND ALL REQUIRED BORROW EXCAVATION, FOR THE SHOULDER STABILIZATION, SHALL BE A SUBSIDIARY OBLIGATION OF ALL OTHER PAY ITEMS

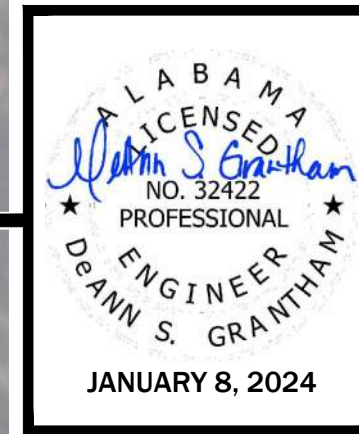

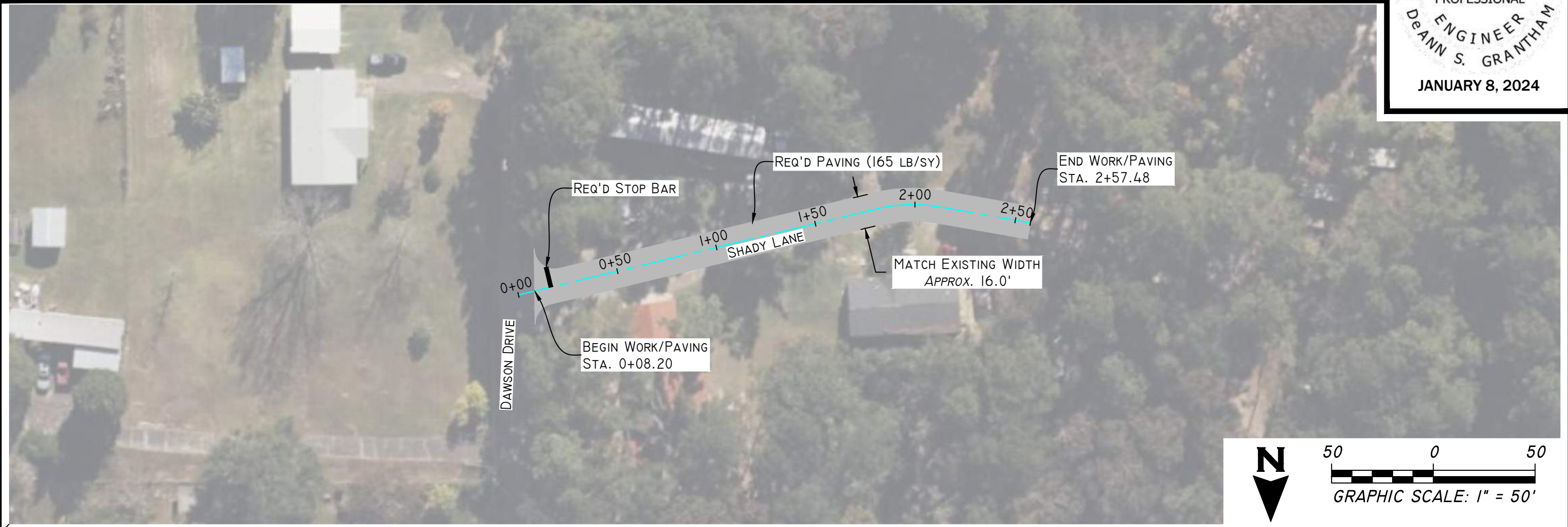
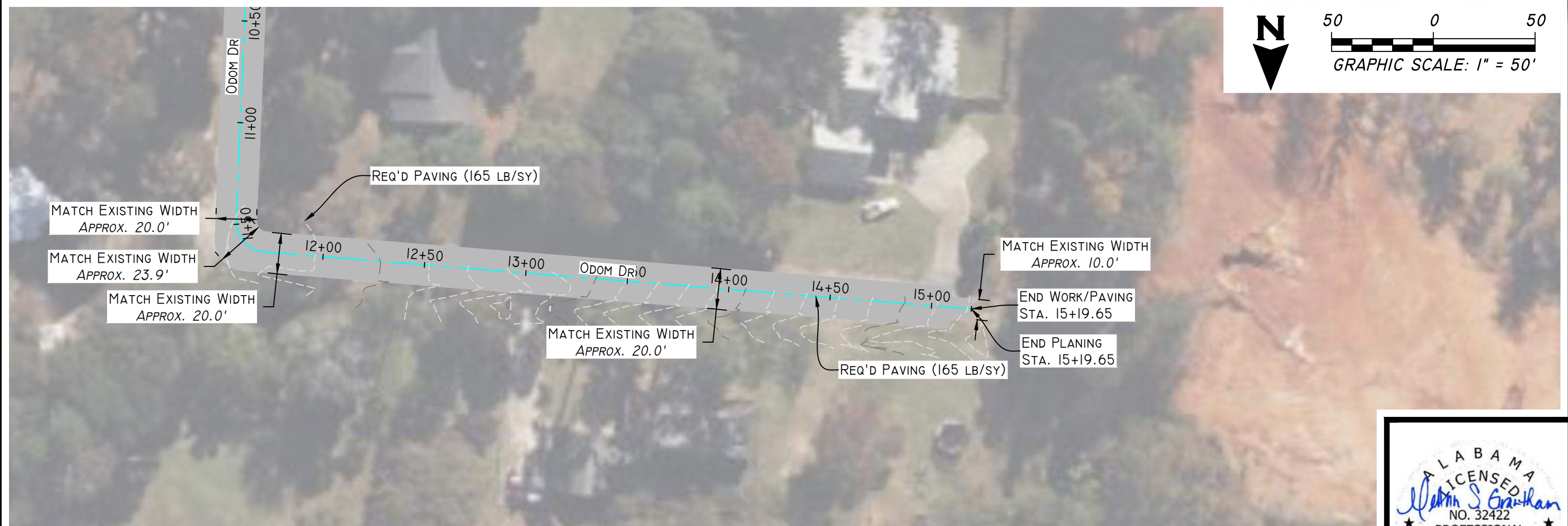

ALABAMA  
 LICENSED  
*Deann S. Grantham*  
 NO. 32422  
 PROFESSIONAL  
 ENGINEER  
 DEANN S. GRANTHAM  
 JANUARY 8, 2024

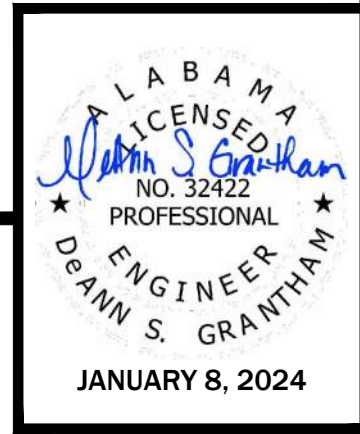
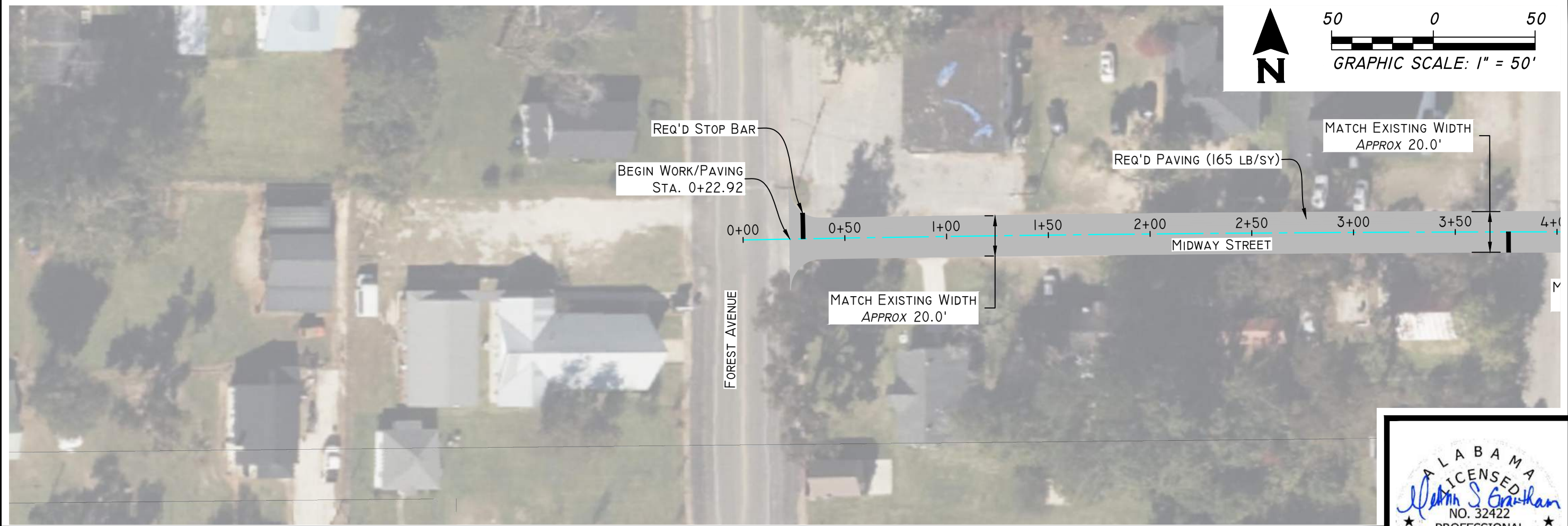

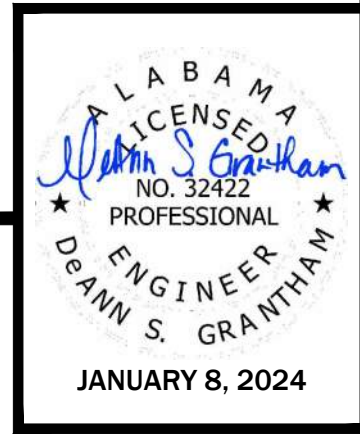
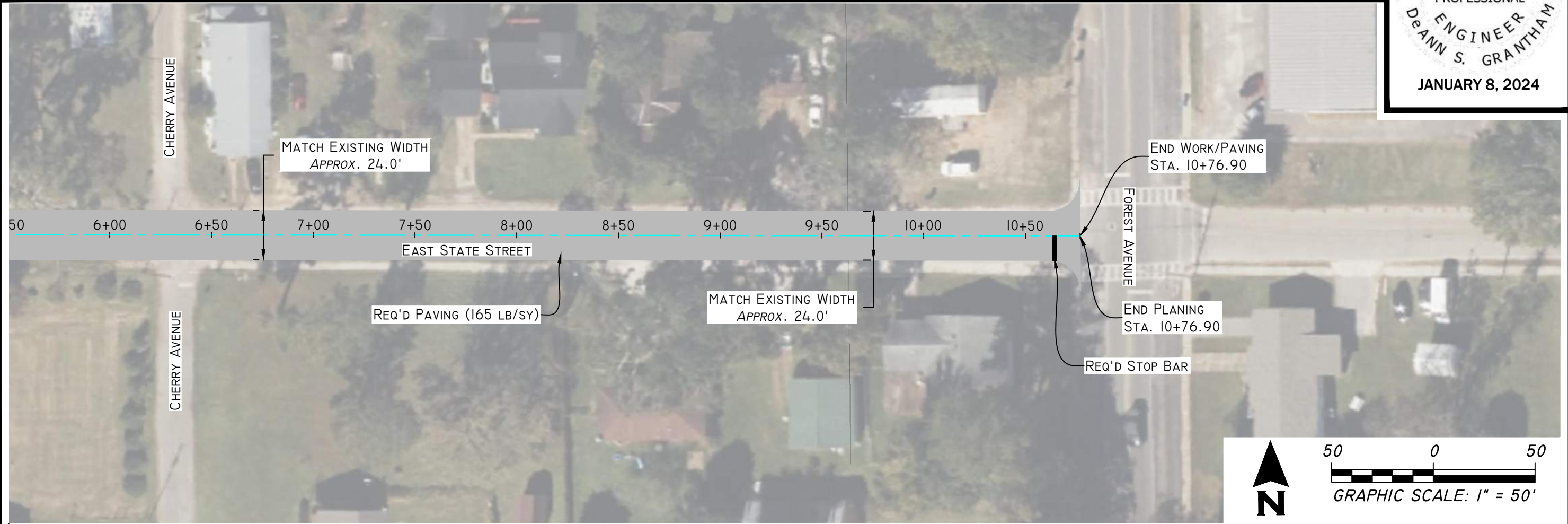



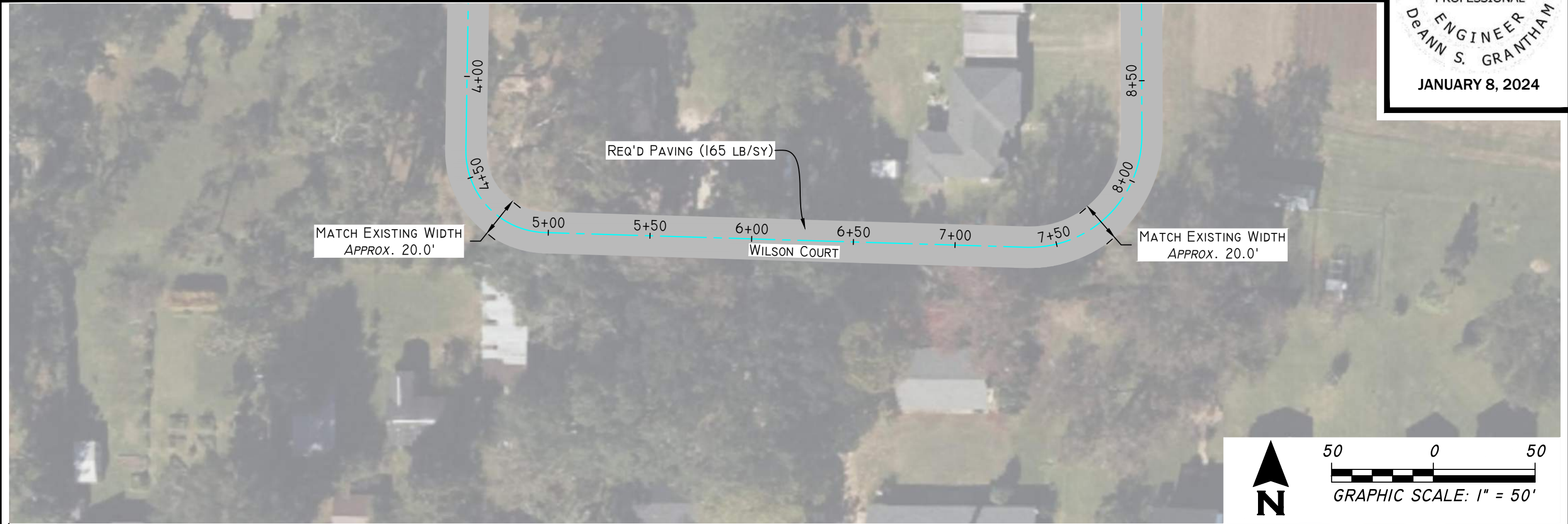

ALABAMA  
 LICENSED  
*Deann S. Grantham*  
 NO. 32422  
 PROFESSIONAL  
 ENGINEER  
 DEANN S. GRANTHAM  
 JANUARY 8, 2024

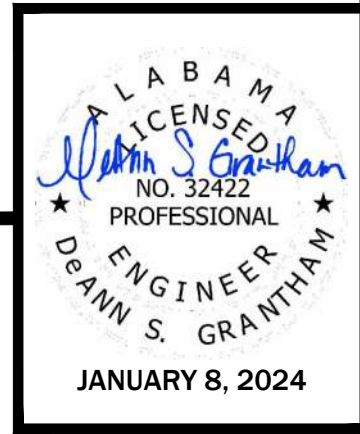
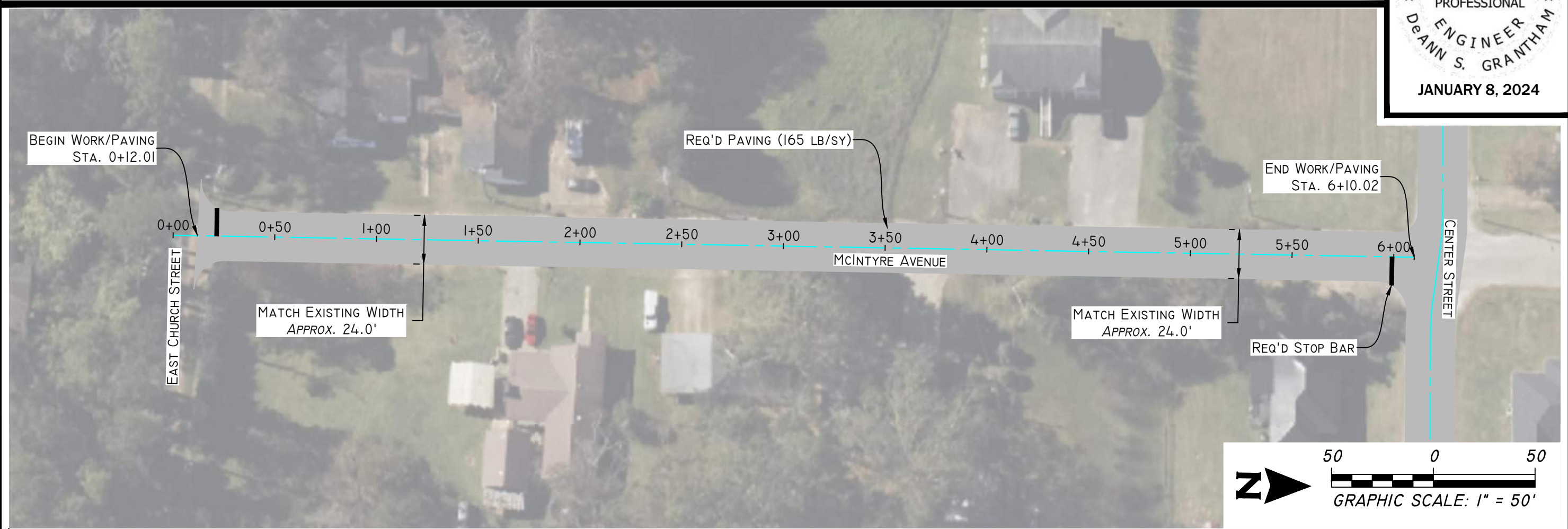
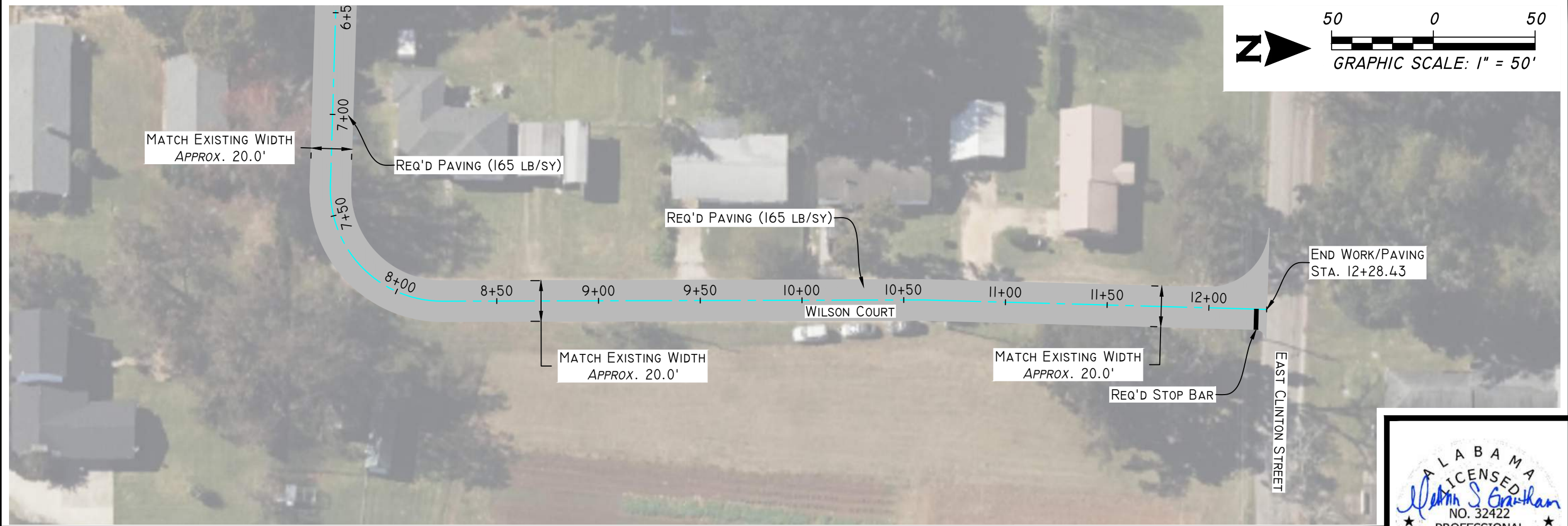

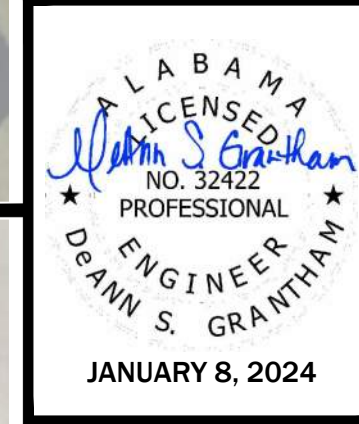
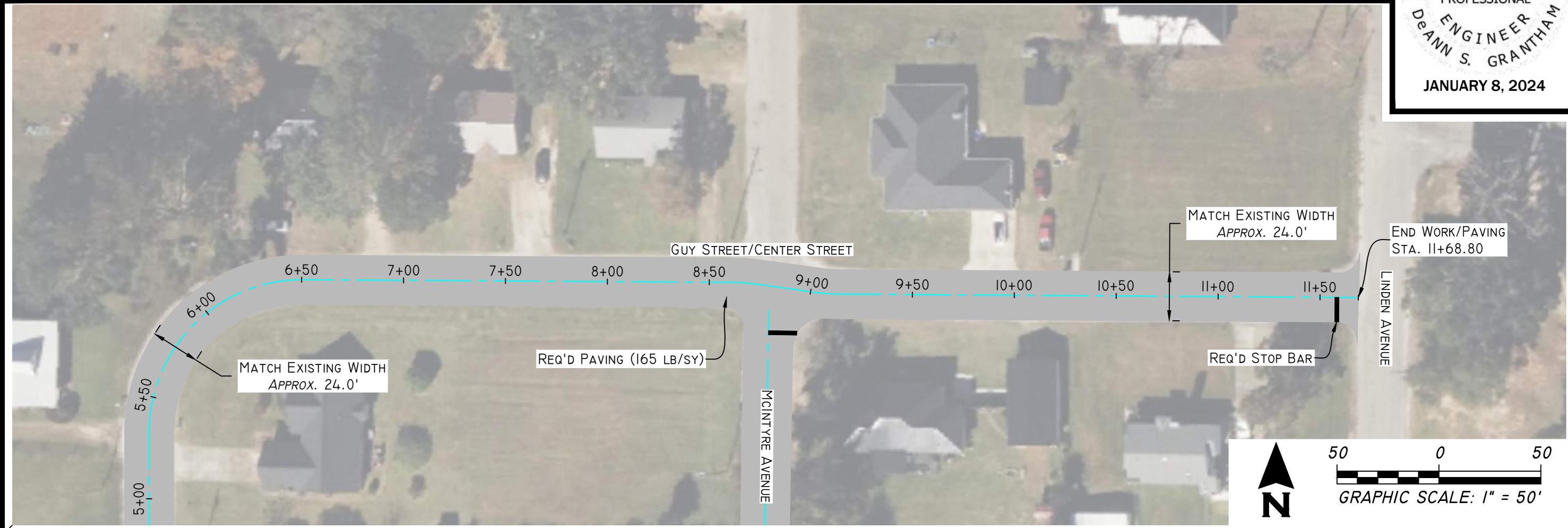
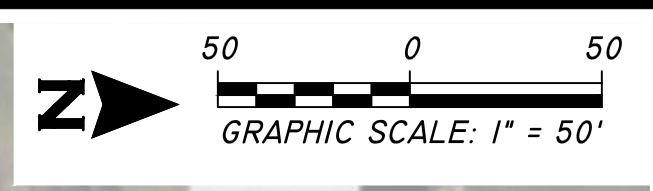

DESIGNED BY	DSG
DRAWN BY	JAC
DATE	JAN. 2024
CADD FILE	JACKSON RAA
PROJECT NO	2349101
REVISED	*
SHEET	14 OF 32

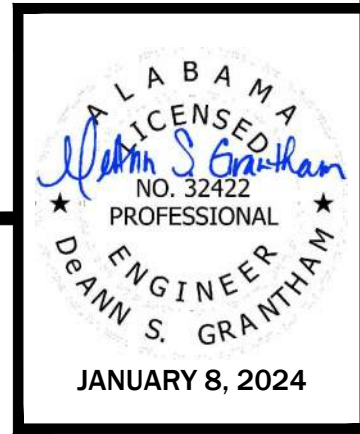
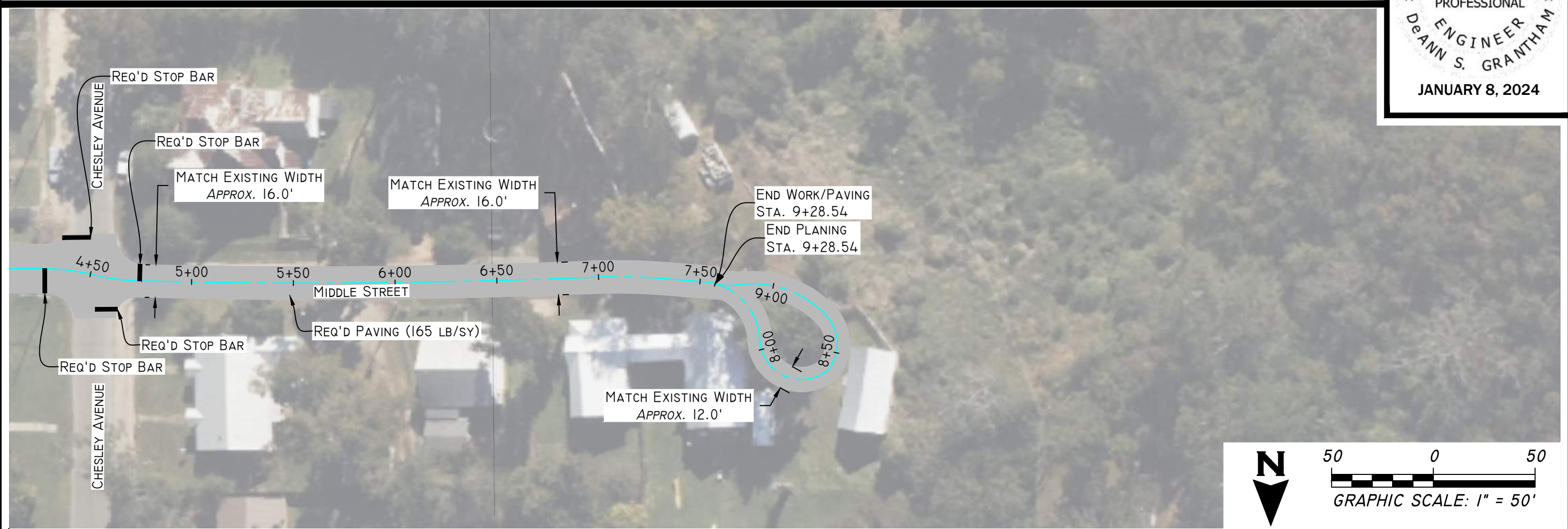
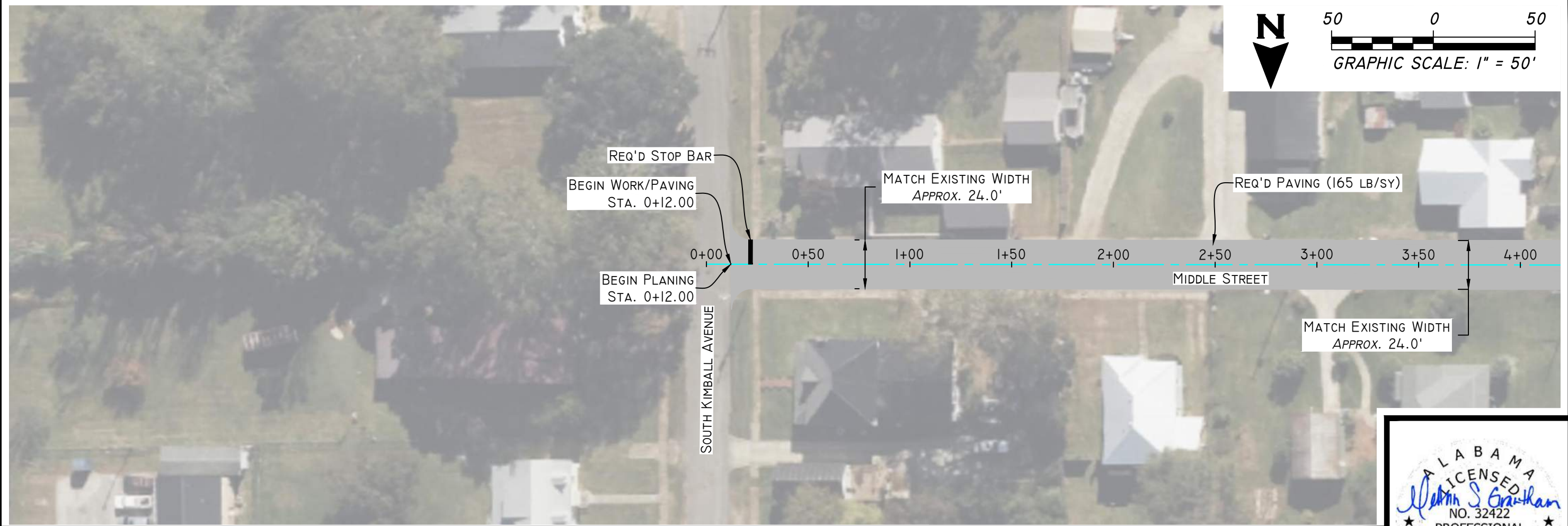

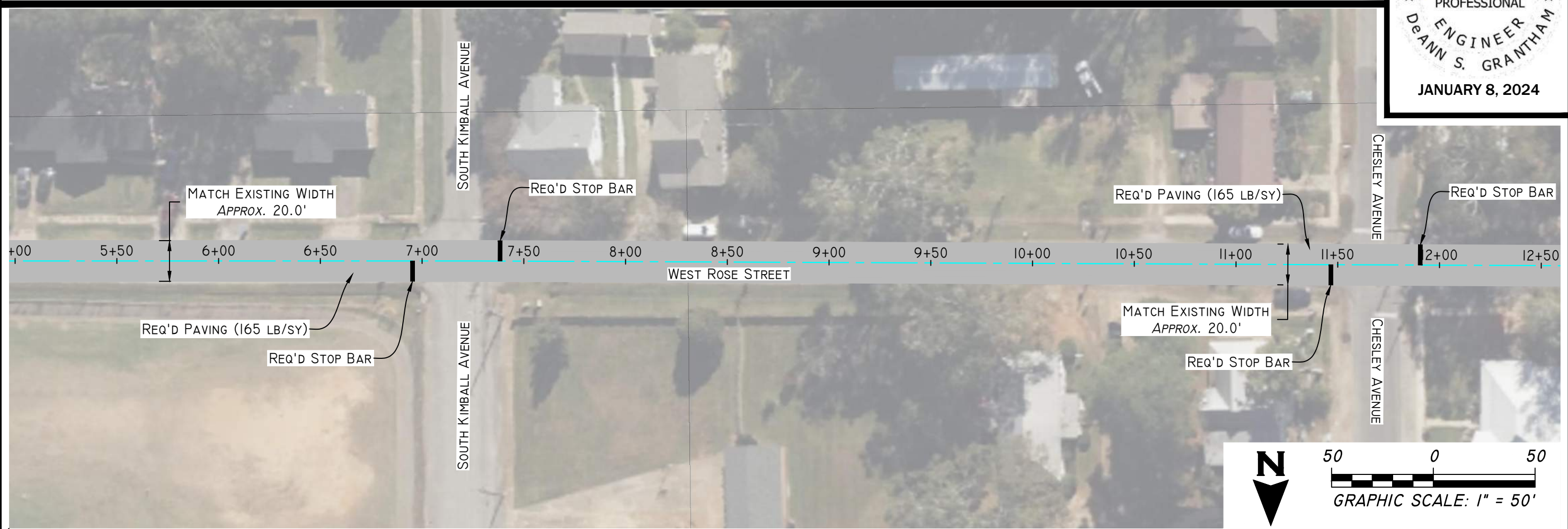

ALABAMA  
 LICENSED  
*Deann S. Grantham*  
 NO. 32422  
 PROFESSIONAL  
 ENGINEER  
 DEANN S. GRANTHAM  
 JANUARY 8, 2024

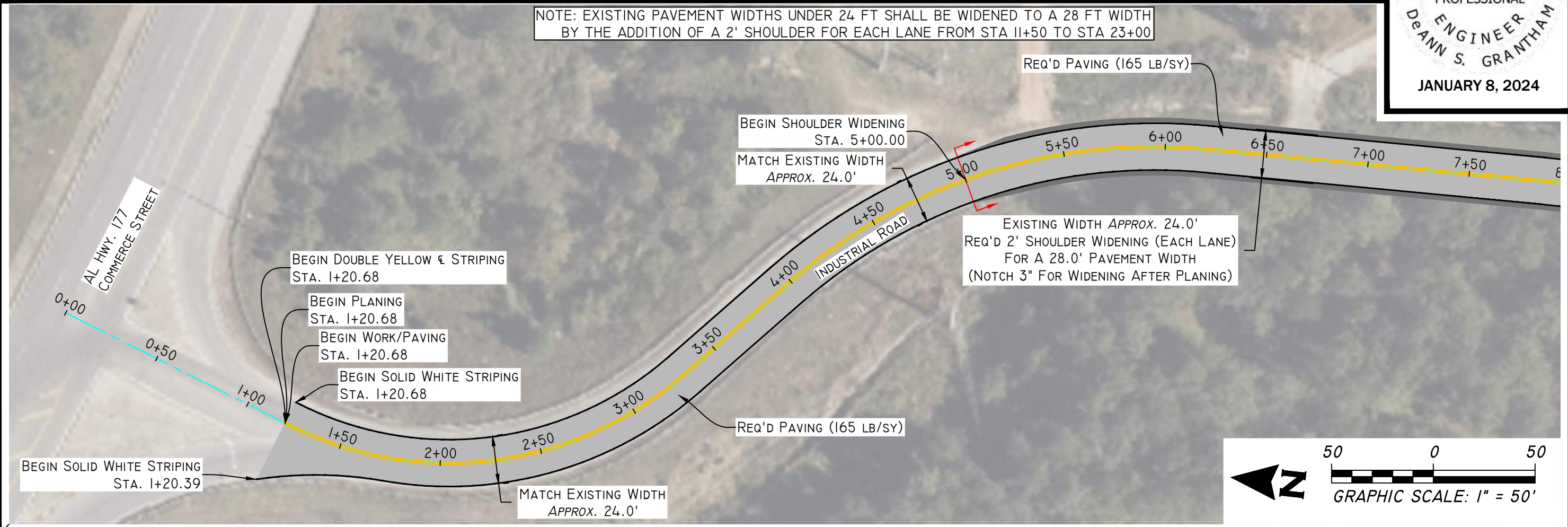
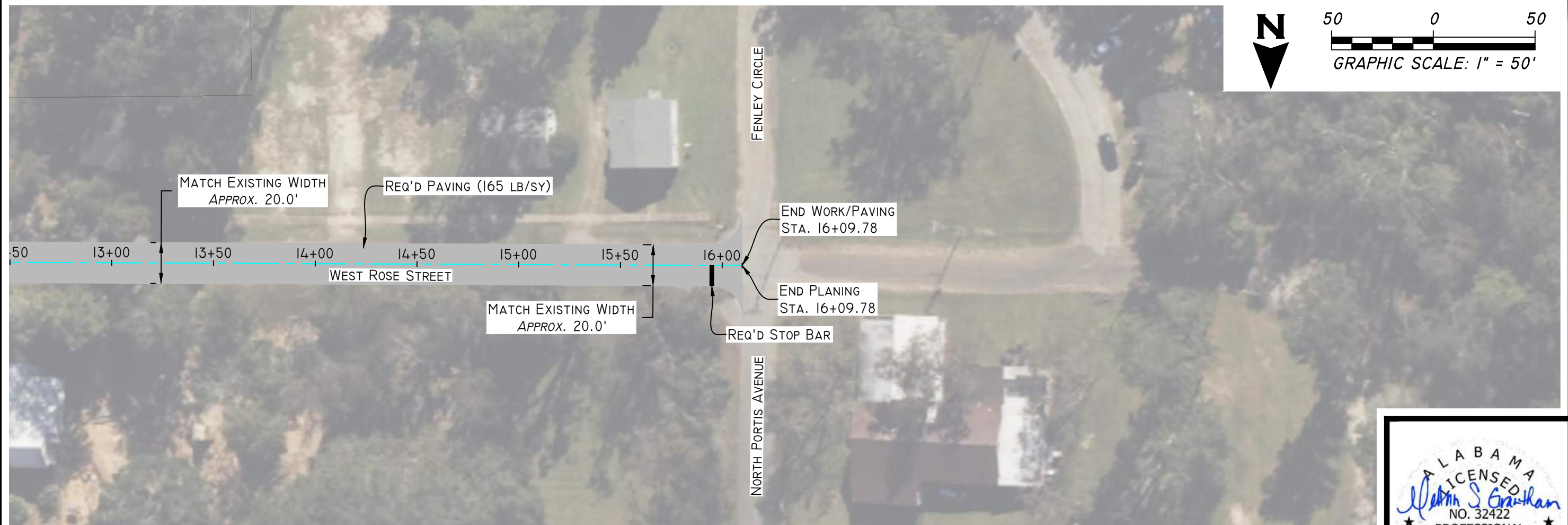

NOTE: EXISTING PAVEMENT WIDTHS UNDER 24 FT SHALL BE WIDENED TO A 28 FT WIDTH BY THE ADDITION OF A 2' SHOULDER FOR EACH LANE FROM STA 11+50 TO STA 23+00

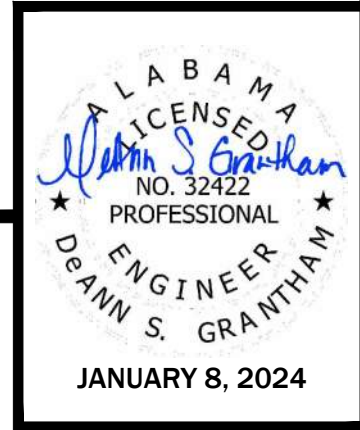

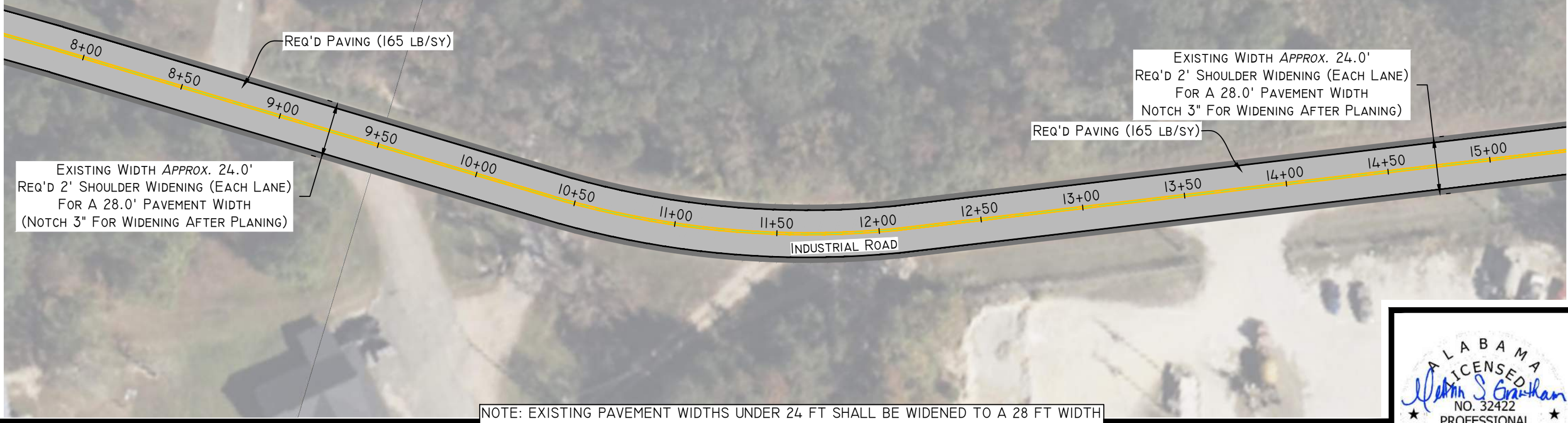

NOTE: EXISTING PAVEMENT WIDTHS UNDER 24 FT SHALL BE WIDENED TO A 28 FT WIDTH BY THE ADDITION OF A 2' SHOULDER FOR EACH LANE FROM STA 11+50 TO STA 23+00

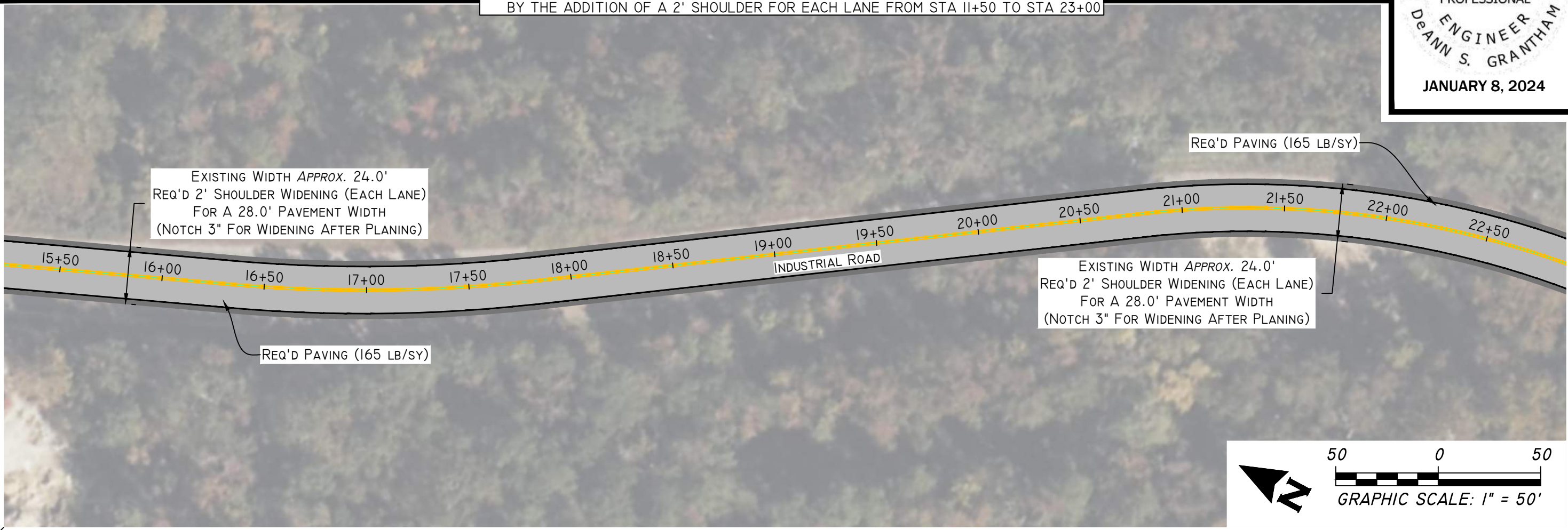
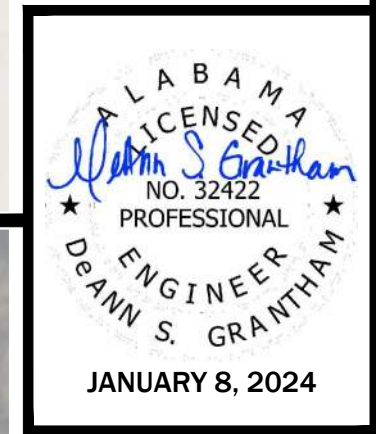

NOTE: EXISTING PAVEMENT WIDTHS UNDER 24 FT SHALL BE WIDENED TO A 28 FT WIDTH BY THE ADDITION OF A 2' SHOULDER FOR EACH LANE FROM STA 5+00 TO STA 27+19.38

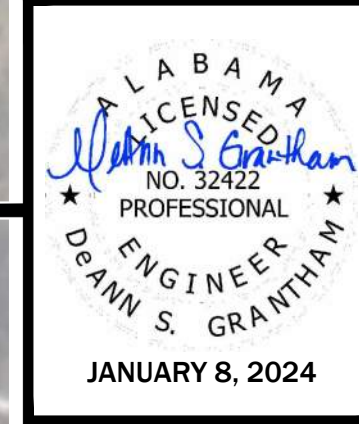
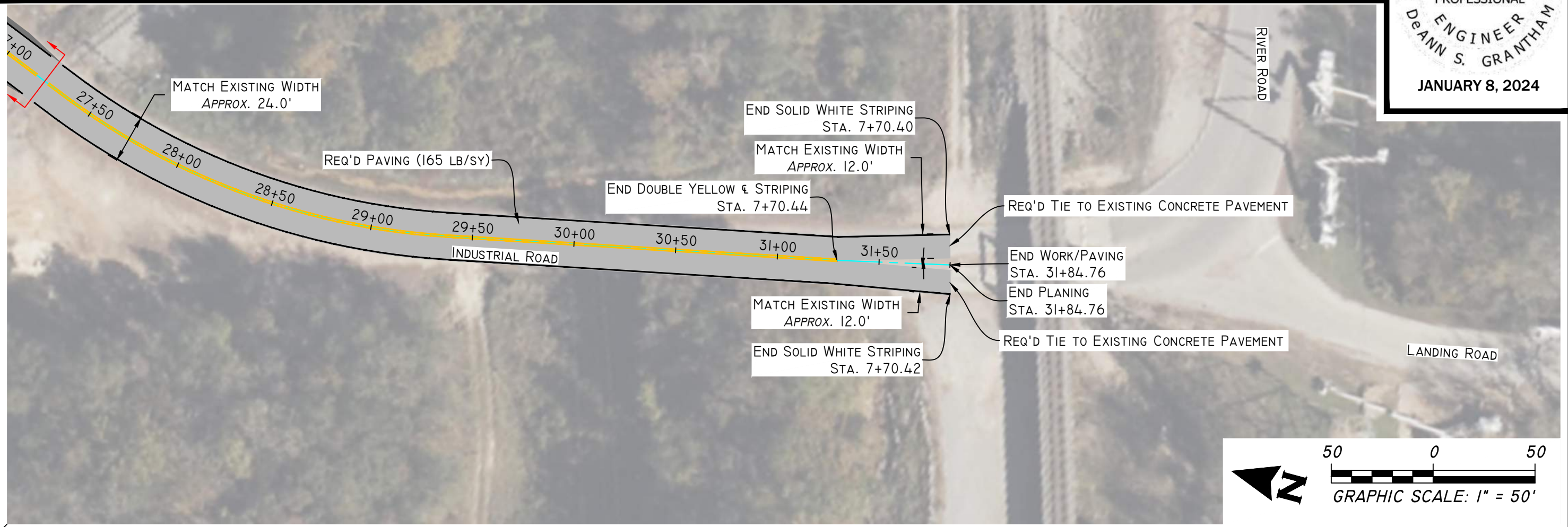
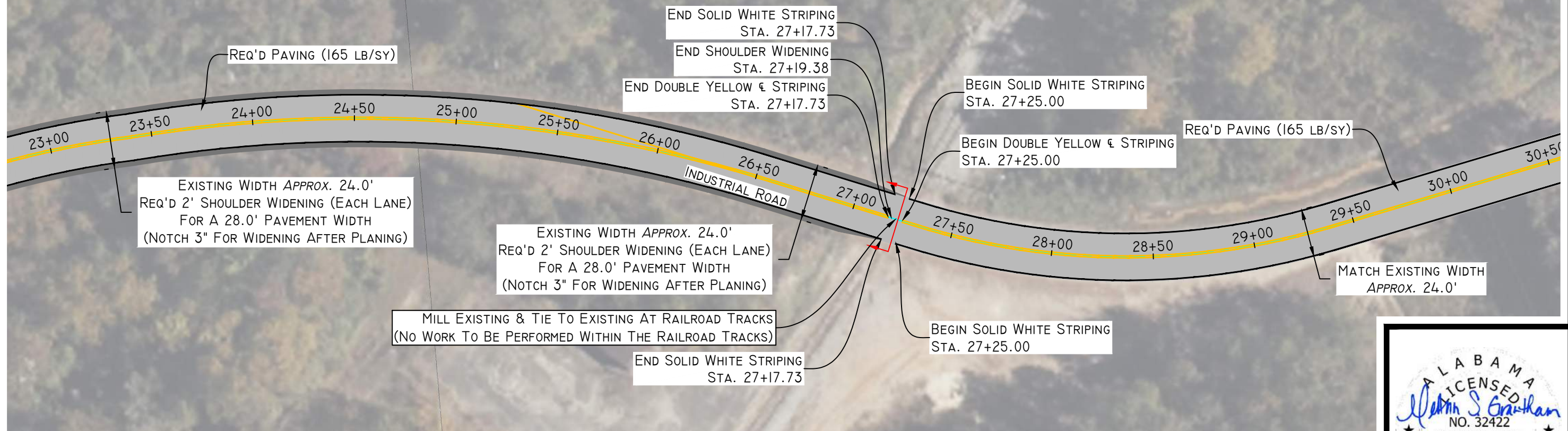



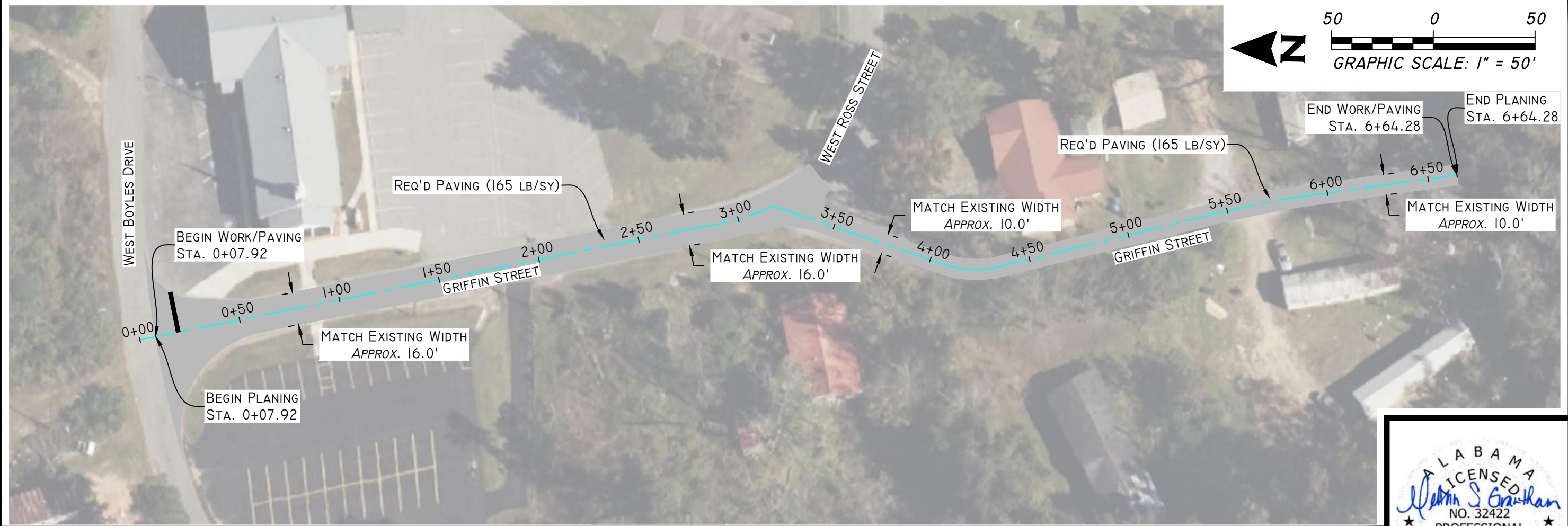

ALABAMA  
 LICENSED  
*Deann S. Grantham*  
 NO. 32422  
 PROFESSIONAL  
 ENGINEER  
 DEANN S. GRANTHAM  
 ★ ★  
 JANUARY 8, 2024

**SOUTHERN ENGINEERING SOLUTIONS**  
 Phone 334.222.1849  
 Fax 334.222.1869  
 www.southernengineeringsolutions.com  
 201 East Troy Street  
 P.O. Box 610  
 Andalusia, AL 36620

**INDUSTRIAL ROAD PAVING LAYOUT**  
**STREET RESURFACING & DRAINAGE REPAIRS**  
**JACKSON, ALABAMA**

DESIGNED BY	DSG
DRAWN BY	JAC
DATE	JAN. 2024
CADD FILE	JACKSON RAA
PROJECT NO	2349101
REVISED	*
SHEET	20 OF 32

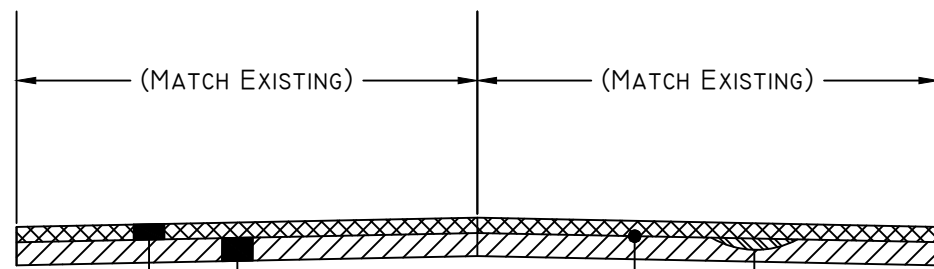

TYPICAL SECTION (SHADY LANE, MIDWAY STREET, WILSON COURT, MCINTYRE AVENUE, GUY STREET, & CENTER STREET)

DESCRIPTION

- ①- SUPERPAVE BITUMINOUS CONCRETE WEARING SURFACE LAYER, 1/2" MAXIMUM AGGREGATE SIZE MIX, ESAL RANGE A/B (I65 LB/SY)
- ②- TACK COAT (PAID AS SUBSIDIARY TO WEARING SURFACE)
- ③- SUPERPAVE BITUMINOUS UPPER BINDER LAYER, LEVELING, 1/2" MAXIMUM AGGREGATE SIZE MIX, ESAL RANGE A/B
- A- EXISTING BITUMINOUS ASPHALT PAVEMENT

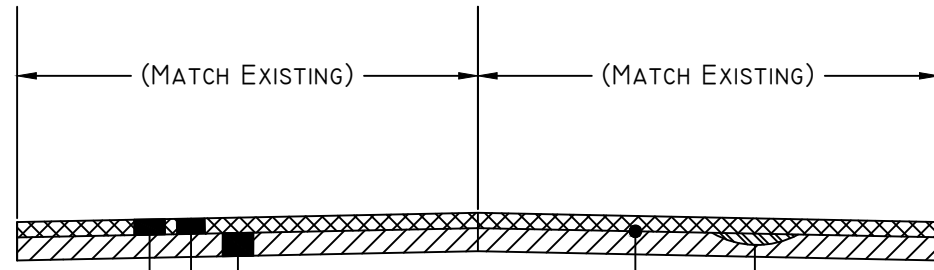

TYPICAL SECTION (STANLEY DRIVE, ODOM DRIVE, EAST STATE STREET, MIDDLE STREET, WEST ROSE STREET, & GRIFFIN STREET)

DESCRIPTION

- ①- SUPERPAVE BITUMINOUS CONCRETE WEARING SURFACE LAYER, 1/2" MAXIMUM AGGREGATE SIZE MIX, ESAL RANGE A/B (I65 LB/SY)
- ②- TACK COAT (PAID AS SUBSIDIARY TO WEARING SURFACE)
- ③- SUPERPAVE BITUMINOUS UPPER BINDER LAYER, LEVELING, 1/2" MAXIMUM AGGREGATE SIZE MIX, ESAL RANGE A/B
- ⑤- PLANING EXISTING PAVEMENT (APPROXIMATELY 1.10" THRU 2.0" THICK)
- A- EXISTING BITUMINOUS ASPHALT PAVEMENT

NOTES:

1. PROVIDE CLEAN, STRAIGHT SAWCUT EDGE AND JOINT SEALER BETWEEN ANY EXISTING AND NEW ASPHALT. COST AND LABOR FOR THIS PROCESS SHOULD BE INCLUDED IN PRICE FOR OTHER PAVING MATERIALS.
2. PROVIDE A SMOOTH SEAM/TRANSITION BETWEEN EXISTING ROADWAY AND PROPOSED ASPHALT.
3. MAINTAIN PUBLIC ROADWAYS FREE OF DEBRIS AND DIRT.
4. TOPSOIL SHALL BE USED TO BRING THE SHOULDERS LEVEL TO NEW PAVEMENT

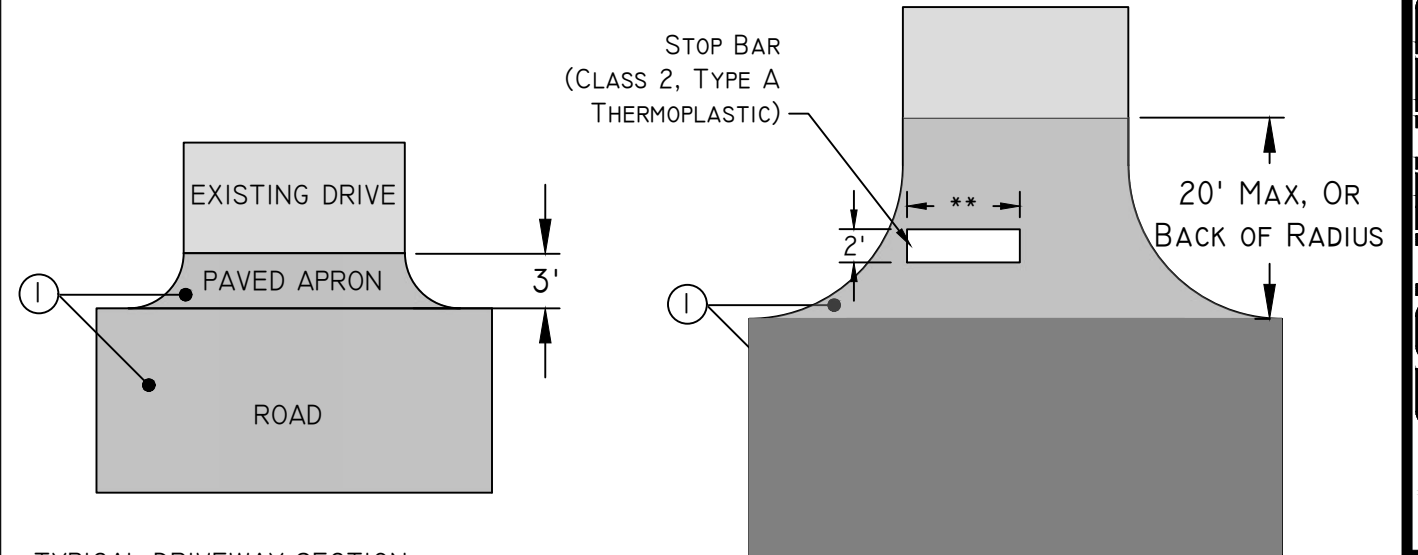

TYPICAL DRIVEWAY SECTION

\*TYPICAL PAVED APRON LENGTH SHALL BE 3' MINIMUM (OR AS DIRECTED BY ENGINEER)

TYPICAL SIDE STREET DETAIL

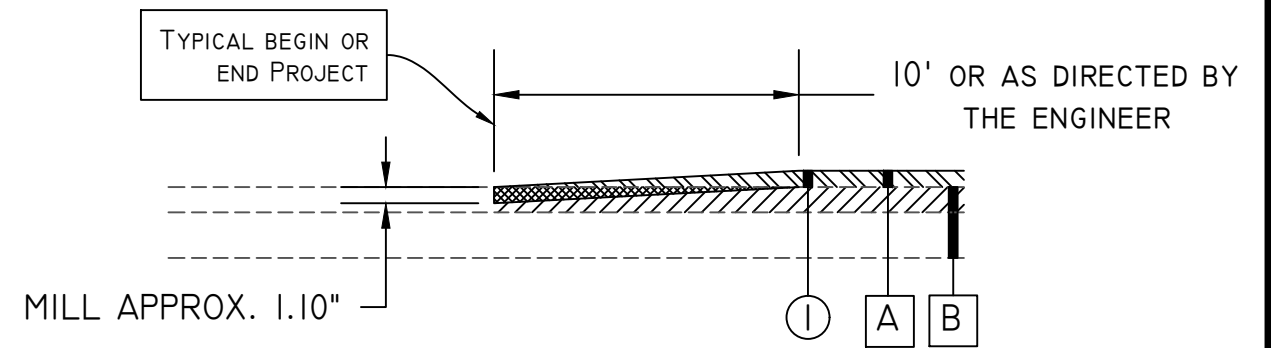

TYPICAL BEGIN/END PROJECT IN OVERLAY SECTIONS

NOT TO SCALE

LEGEND

- ①- SUPERPAVE BITUMINOUS CONCRETE WEARING SURFACE LAYER, 1/2" MAXIMUM AGGREGATE SIZE MIX, ESAL RANGE A/B (I65 LB/SY)
- A- REQUIRED PLANING (1.1" THRU 2.0" THICK)
- B- EXISTING BITUMINOUS ASPHALT PAVEMENT/BASE (TO REMAIN)



JANUARY 8, 2024

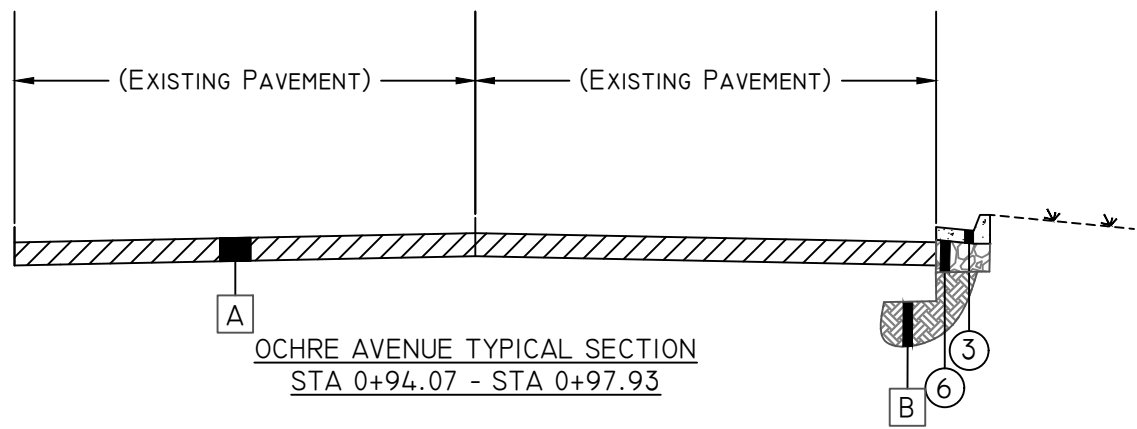

OCHRE AVENUE TYPICAL SECTION  
STA 0+94.07 - STA 0+97.93

DESCRIPTION

- ③- COMBINATION CURB & GUTTER, TYPE C (MODIFIED)
- ⑥- CRUSHED AGGREGATE BASE COURSE, 825 B, 6" COMPACTED THICKNESS (OR APPROVED EQUAL), COMPACTED TO 100% OF AASHTO T-180 SPECS
- A - EXISTING BITUMINOUS ASPHALT PAVEMENT
- B - EXISTING SUB-BASE TO BE COMPACTED TO 98% OF AASHTO T-99 SPECS

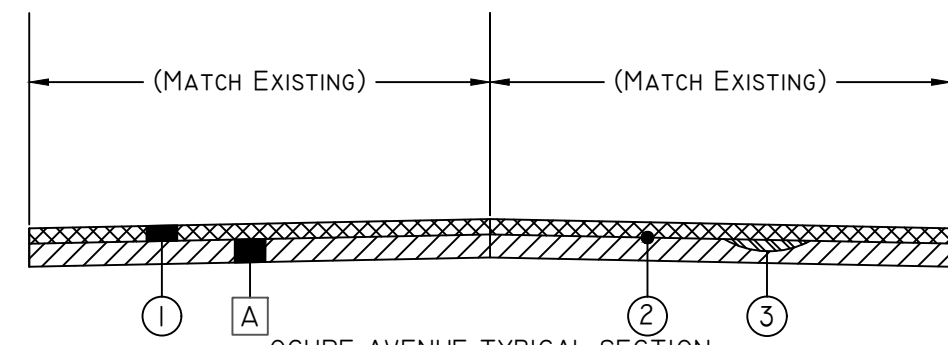

OCHRE AVENUE TYPICAL SECTION  
STA 3+65.68 - STA 8+47.52

DESCRIPTION

- ①- SUPERPAVE BITUMINOUS CONCRETE WEARING SURFACE LAYER, 1/2" MAXIMUM AGGREGATE SIZE MIX, ESAL RANGE A/B (165 LB/SY)
- ②- TACK COAT (PAID AS SUBSIDIARY TO WEARING SURFACE)
- ③- SUPERPAVE BITUMINOUS UPPER BINDER LAYER, LEVELING, 1/2" MAXIMUM AGGREGATE SIZE MIX, ESAL RANGE A/B
- A - EXISTING BITUMINOUS ASPHALT PAVEMENT

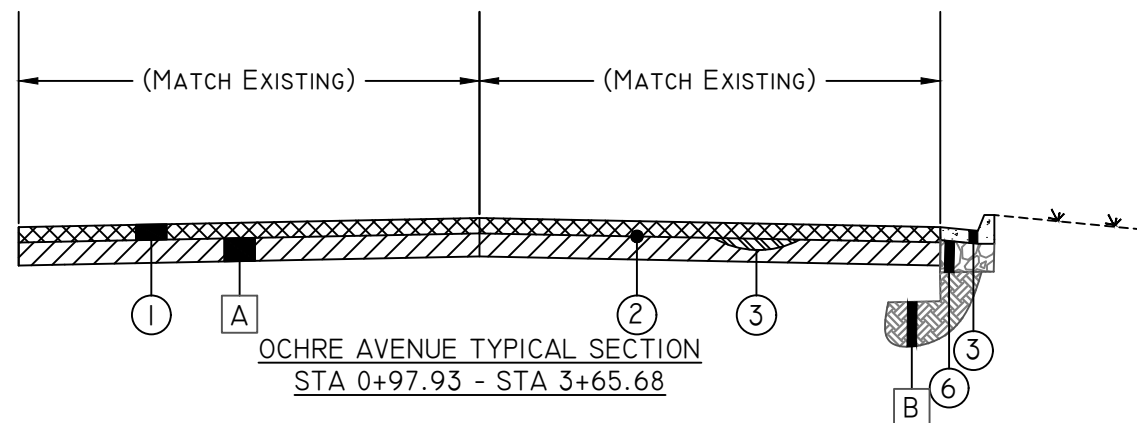

OCHRE AVENUE TYPICAL SECTION  
STA 0+97.93 - STA 3+65.68

DESCRIPTION

- ①- SUPERPAVE BITUMINOUS CONCRETE WEARING SURFACE LAYER, 1/2" MAXIMUM AGGREGATE SIZE MIX, ESAL RANGE A/B (165 LB/SY)
- ②- TACK COAT (PAID AS SUBSIDIARY TO WEARING SURFACE)
- ③- COMBINATION CURB & GUTTER, TYPE C (MODIFIED)
- ⑥- CRUSHED AGGREGATE BASE COURSE, 825 B, 6" COMPACTED THICKNESS (OR APPROVED EQUAL), COMPACTED TO 100% OF AASHTO T-180 SPECS
- A - EXISTING BITUMINOUS ASPHALT PAVEMENT
- B - EXISTING SUB-BASE TO BE COMPACTED TO 98% OF AASHTO T-99 SPECS

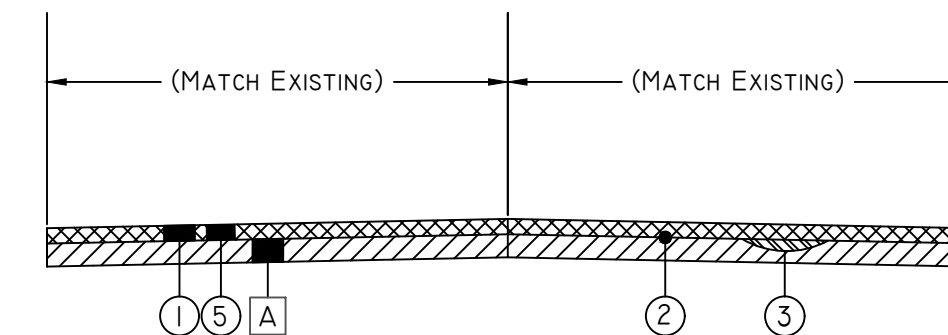

OCHRE AVENUE TYPICAL SECTION  
STA 8+47.52 - STA 11+88.98

DESCRIPTION

- ①- SUPERPAVE BITUMINOUS CONCRETE WEARING SURFACE LAYER, 1/2" MAXIMUM AGGREGATE SIZE MIX, ESAL RANGE A/B (165 LB/SY)
- ②- TACK COAT (PAID AS SUBSIDIARY TO WEARING SURFACE)
- ③- SUPERPAVE BITUMINOUS UPPER BINDER LAYER, LEVELING, 1/2" MAXIMUM AGGREGATE SIZE MIX, ESAL RANGE A/B
- ⑤- PLANING EXISTING PAVEMENT (APPROXIMATELY 1.10" THRU 2.0" THICK)
- A - EXISTING BITUMINOUS ASPHALT PAVEMENT

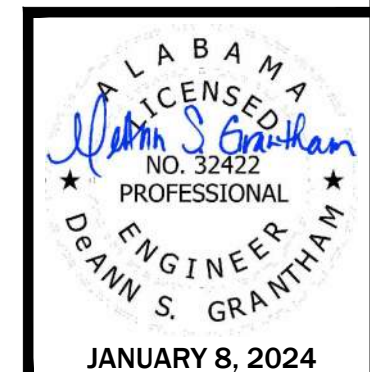

DESIGNED BY	DSG
DRAWN BY	JAC
DATE	JAN. 2024
CADD FILE	JACKSON RAA
PROJECT NO	2349101
REVISED	*
SHEET	22 OF 32

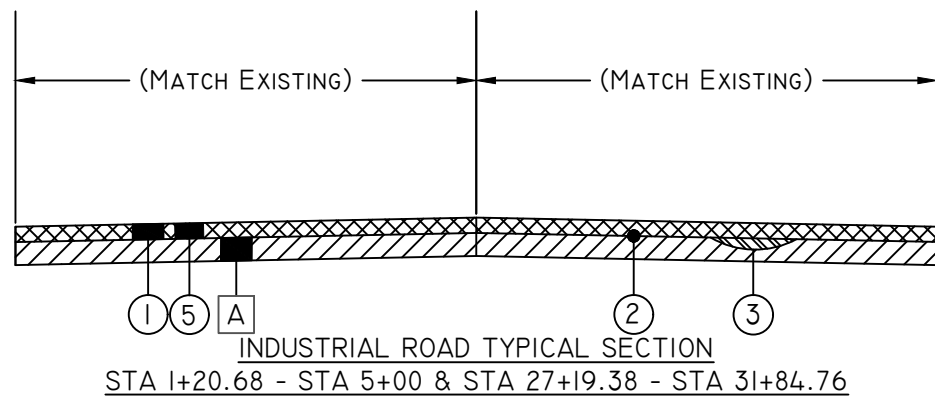

**DESCRIPTION**

- ①- SUPERPAVE BITUMINOUS CONCRETE WEARING SURFACE LAYER, 1/2" MAXIMUM AGGREGATE SIZE MIX, ESAL RANGE C/D (165 LB/SY)
- ②- TACK COAT (PAID AS SUBSIDIARY TO WEARING SURFACE)
- ③- SUPERPAVE BITUMINOUS UPPER BINDER LAYER, LEVELING, 1/2" MAXIMUM AGGREGATE SIZE MIX, ESAL RANGE A/B
- ⑤- PLANING EXISTING PAVEMENT (APPROXIMATELY 1.10" THRU 2.0" THICK)
- A - EXISTING BITUMINOUS ASPHALT PAVEMENT

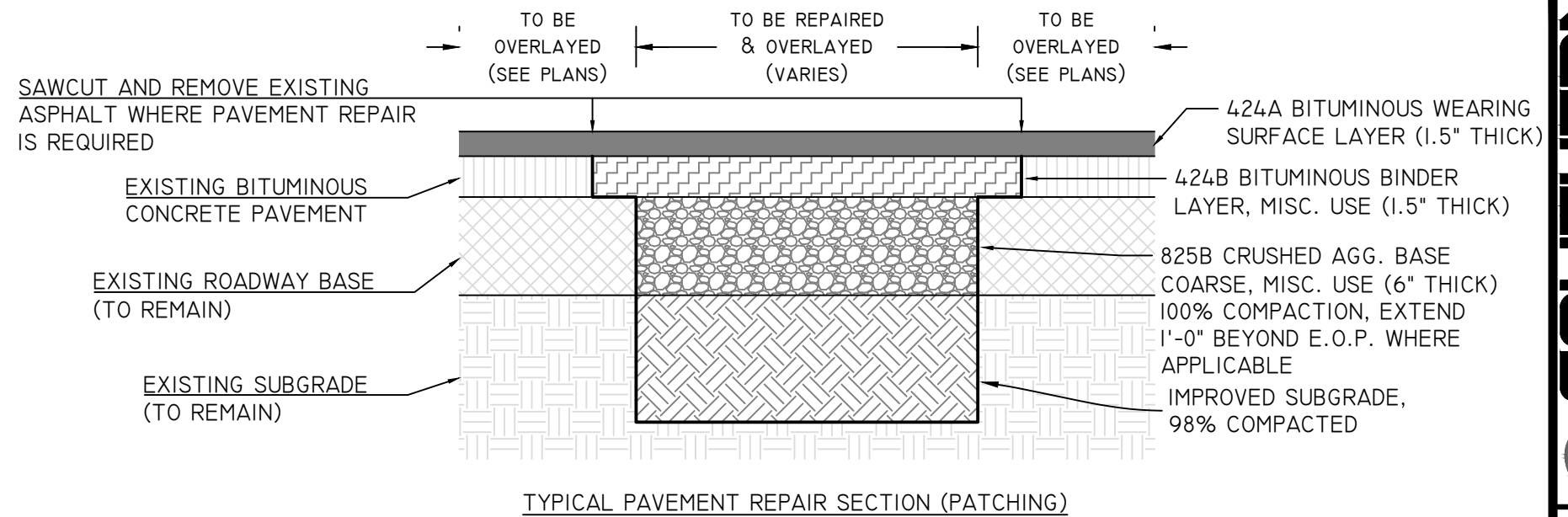

**TYPICAL PAVEMENT REPAIR SECTION (PATCHING)**

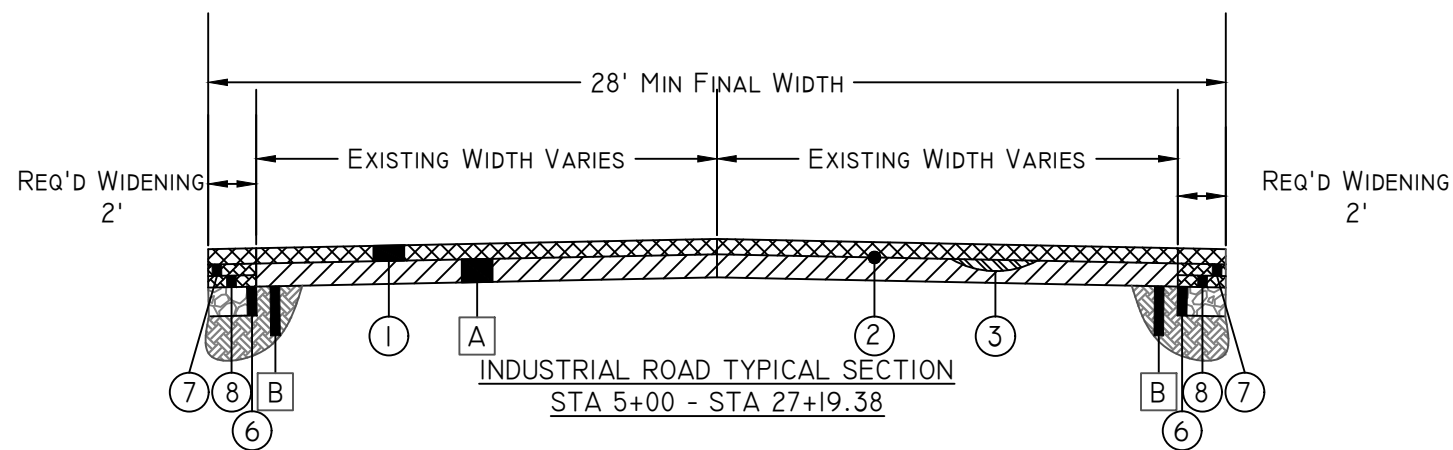

**DESCRIPTION**

- ①- SUPERPAVE BITUMINOUS CONCRETE WEARING SURFACE LAYER, 1/2" MAXIMUM AGGREGATE SIZE MIX, ESAL RANGE C/D (165 LB/SY)
- ②- TACK COAT (PAID AS SUBSIDIARY TO WEARING SURFACE)
- ③- SUPERPAVE BITUMINOUS UPPER BINDER LAYER, LEVELING, 1/2" MAXIMUM AGGREGATE SIZE MIX, ESAL RANGE A/B
- ⑥- CRUSHED AGGREGATE BASE COURSE, 825 B, 6" COMPACTED THICKNESS (OR APPROVED EQUAL), COMPACTED TO 100% OF AASHTO T-180 SPECS
- ⑦- REQ'D 424B-65I SUPERPAVE BITUMINOUS CONCRETE UPPER BINDER LAYER, WIDENING 1" MAXIMUM AGGREGATE SIZE MIX, ESAL RANGE C/D (330 LB/SY)
- ⑧- REQ'D 424B-68I SUPERPAVE BITUMINOUS CONCRETE LOWER BINDER LAYER, WIDENING 1" MAXIMUM AGGREGATE SIZE MIX, ESAL RANGE C/D (330 LB/SY)
- A - EXISTING BITUMINOUS ASPHALT PAVEMENT
- B - EXISTING SUB-BASE TO BE COMPACTED TO 98% OF AASHTO T-99 SPECS

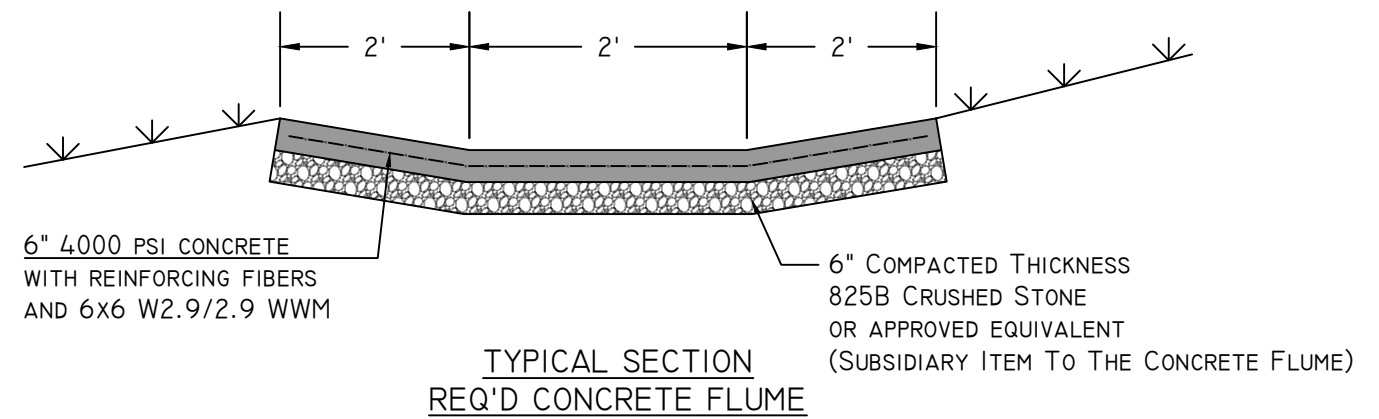

**TYPICAL SECTION REQ'D CONCRETE FLUME**

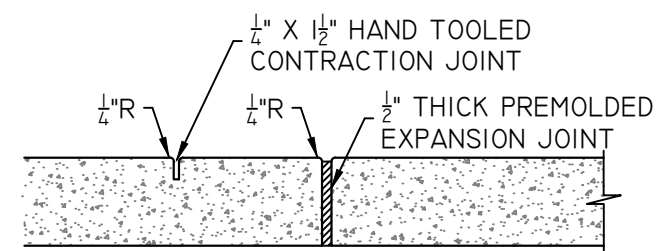

**TYPICAL CONTRACTION & EXPANSION JOINTS**

**NOTE:**  
FOR SPACING REQUIREMENTS SEE SECTION 6.18 OF ADOT STANDARD SPECIFICATIONS FOR HIGHWAY CONSTRUCTION, 2008 EDITION.

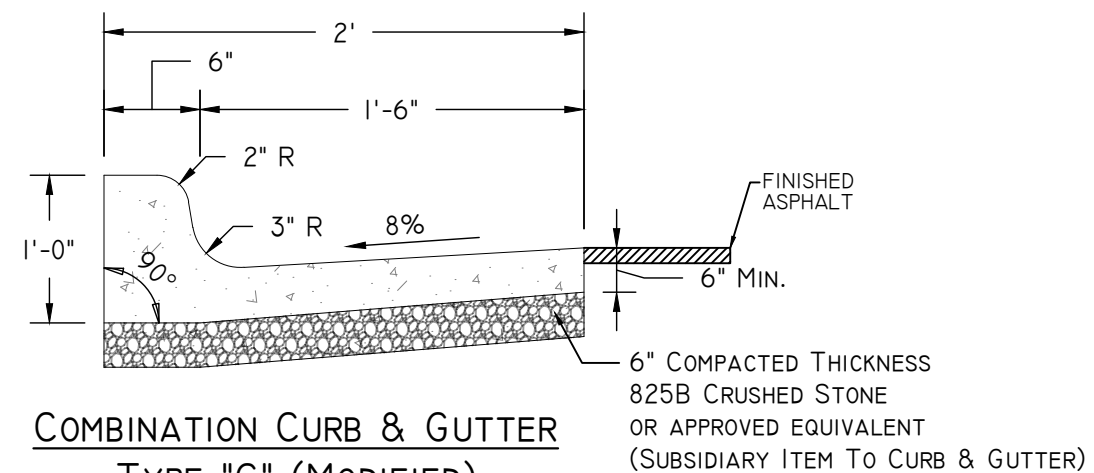

**COMBINATION CURB & GUTTER TYPE "C" (MODIFIED)**

N.T.S.



**JANUARY 8, 2024**

REQUIRED TIGHTLY COMPACTED SOIL BACKFILL, TOP DRESS WITH TOPSOIL AND REQUIRED GRASSING

NOTE: TRENCH WIDTH TO BE SUFFICIENT TO ALLOW FOR PROPER COMPACTION REQUIREMENTS.

BACKFILL TO BE PLACED IN 8" MAX LIFTS AND TIGHTLY COMPACTED

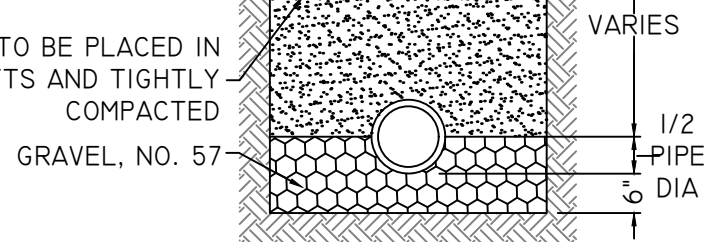

**EMBEDMENT REQUIREMENTS**

FOR PIPE AT ALL DEPTHS NOT UNDER PAVEMENT

NOTE:

\*ALL MATERIALS NEEDED FOR THE PIPE EMBEDMENT ARE TO BE A SUBSIDIARY OBLIGATION TO THE INSTALLATION OF THE STORM SEWER

REQUIRED PAVEMENT  
6" CRUSHED AGGREGATE BASE COURSE

NOTE: TRENCH WIDTH TO BE SUFFICIENT TO ALLOW FOR PROPER COMPACTION REQUIREMENTS.

BACKFILL TO BE PLACED IN 6" MAX LIFTS AND COMPACTED TO 98% STANDARD PROCTOR

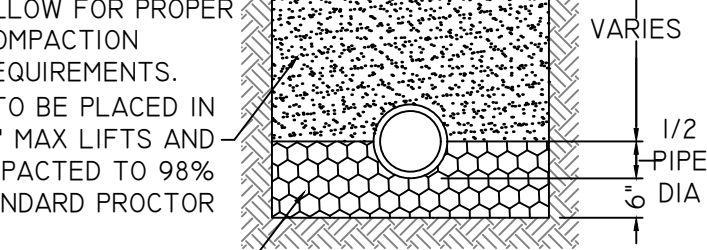

**EMBEDMENT REQUIREMENTS**

FOR PIPE AT ALL DEPTHS UNDER PAVEMENT

NOTE:

\*ALL MATERIALS NEEDED FOR THE PIPE EMBEDMENT ARE TO BE A SUBSIDIARY OBLIGATION TO THE INSTALLATION OF THE STORM SEWER

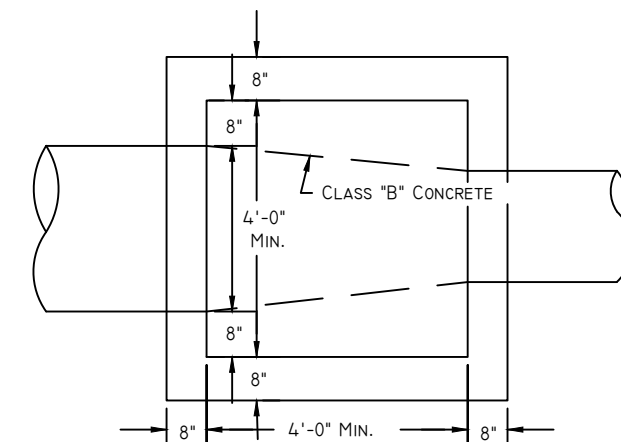

PLAN VIEW

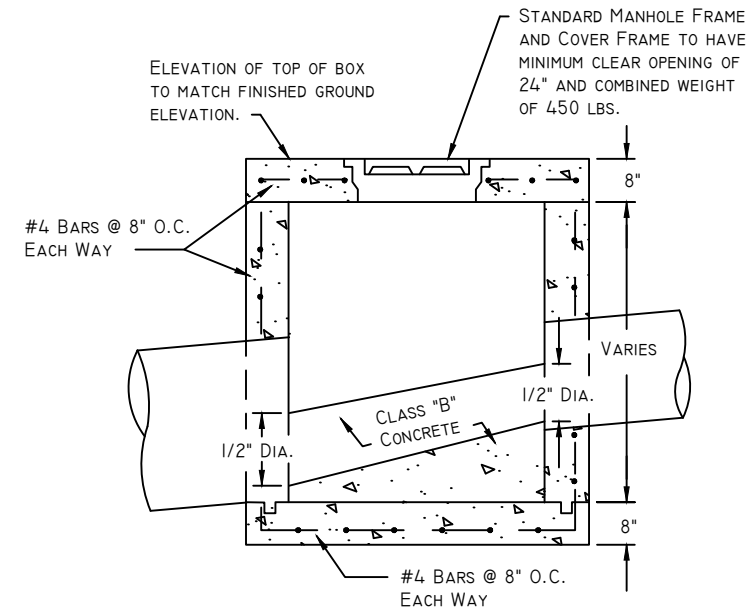

JUNCTION BOX DETAIL  
NOT TO SCALE

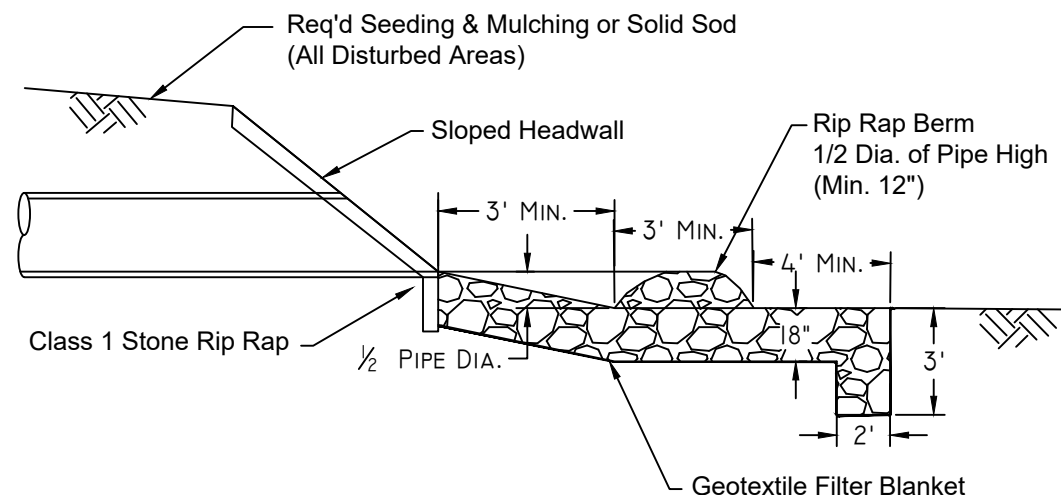

Typical Slope Paved Headwall Rip Rap Pipe Discharge Outlet Energy Dissipator  
Not to Scale



JANUARY 8, 2024

DESIGNED BY	DSG
DRAWN BY	JAC
DATE	JAN. 2024
CADD FILE	JACKSON RAA
PROJECT NO	2349101
REVISED	*
SHEET	24 OF 32

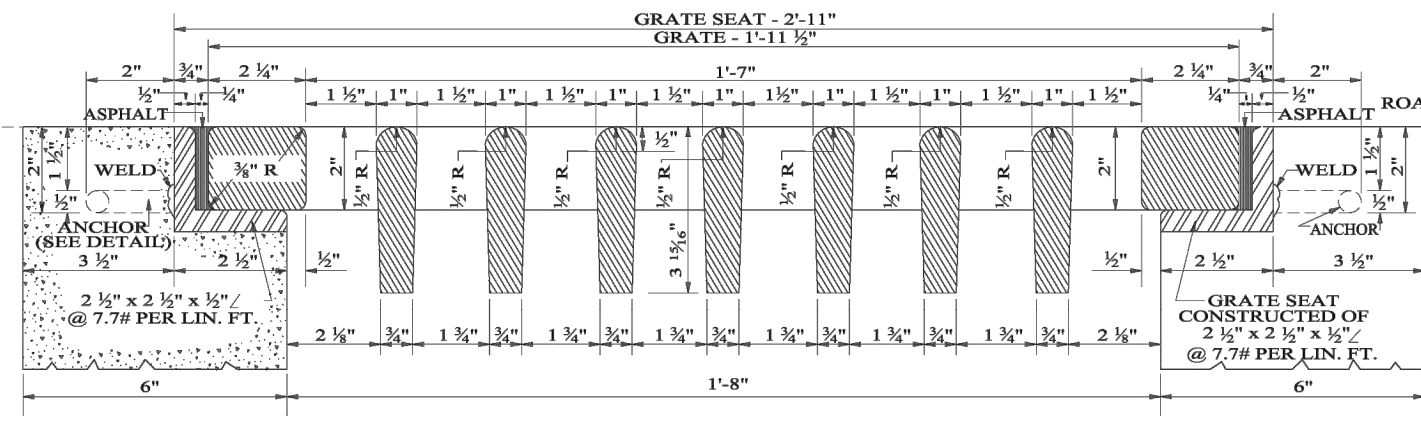

**SECTION "BB" (THROUGH GRATE)**

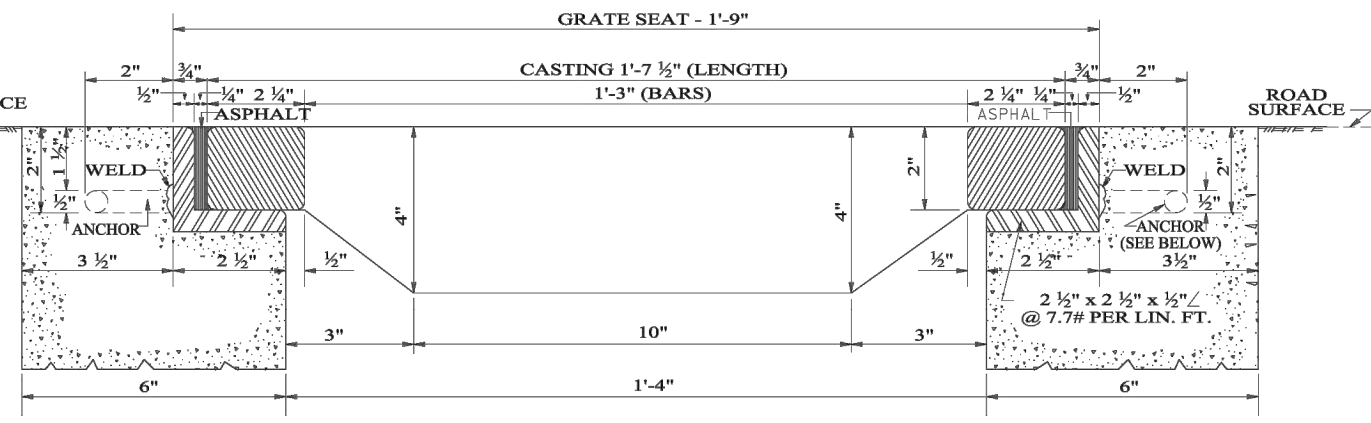

**SECTION "AA" (THROUGH GRATE)**

NOTE: INLETS SHALL BE PLACED IN SUCH MANNER THAT BARS PARALLEL DIRECTION OF PRINCIPAL FLOW.

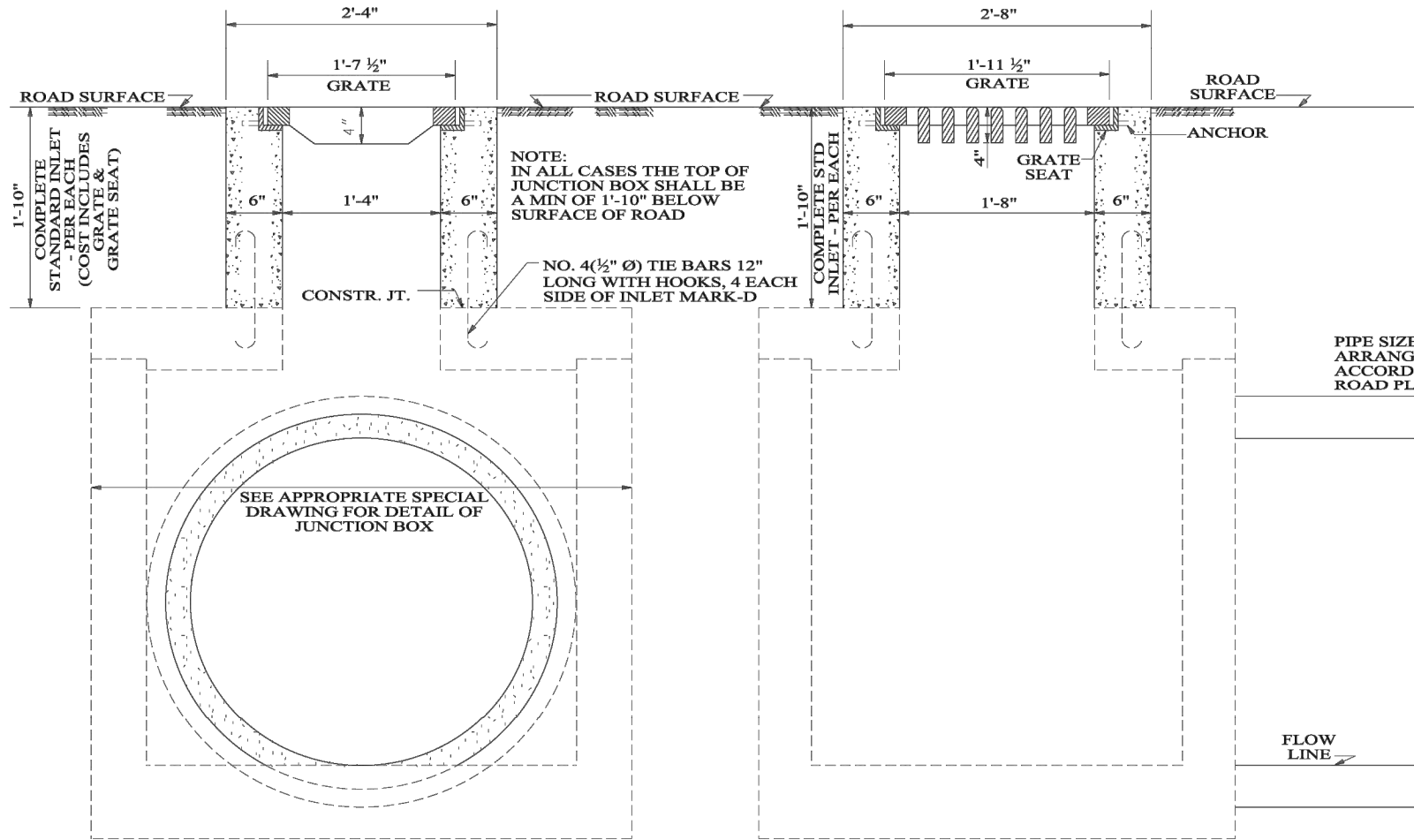

**SECTION "AA"**

**SECTION "BB"**

NOTE: INLET WILL BE PAID FOR "PER EACH" FOR EACH COMPLETE STANDARD INLET AS SHOWN AT SECTIONS "AA" AND "BB" ABOVE. IF COMPLETED STANDARD INLETS REQUIRE GREATER DEPTH THAN SHOWN ON DRAWING, THE EXTRA DEPTH WILL BE PAID FOR UNDER INLET UNITS, FROM A POINT 1'-10" BELOW ROAD SURFACE TO TOP OF JUNCTION BOX INLET. UNITS WILL BE PAID FOR IN INCREMENTS OF 2'-0". ANY FRACTIONAL UNIT LESS THAN 2'-0" WILL BE PAID FOR AS A FULL 2'-0" UNIT.

NOTE: CONTROL POINTS FOR INLETS ARE SURFACE OF ROAD AND FLOW LINE OF PIPE

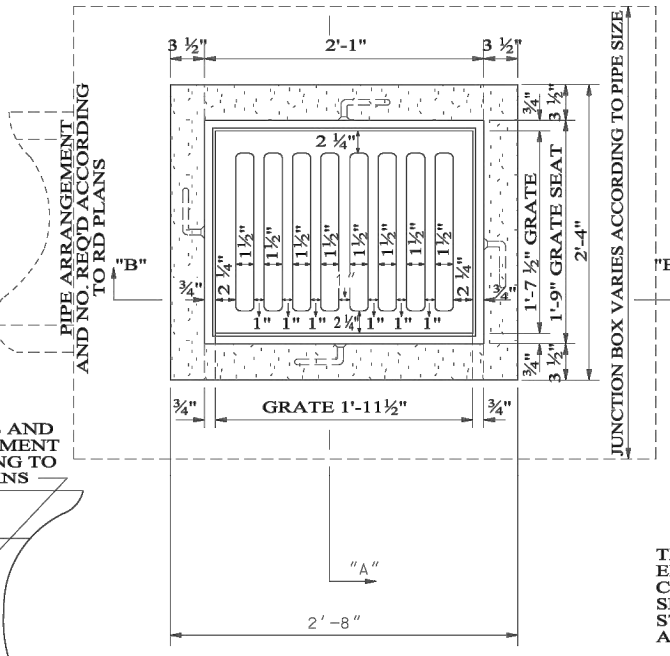

**PLAN VIEW OF INLET AND GRATE**  
 DUCTILE OR MALLEABLE IRON GRATE CASTING

ANCHORS CONSTRUCTED OF NO. 4 (1/2" Ø) REINF BARS BENT TO SHAPE AND WELDED TO GRATE SEAT (4 REQUIRED)  
 GRATE SEAT INCLUDING ANCHORS SHALL BE CLEANED AND GALVANIZED AFTER WELDING

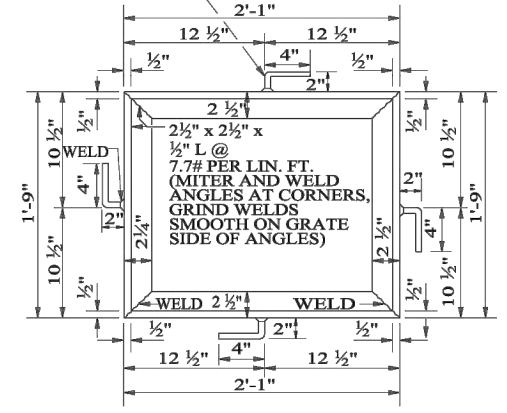

**PLAN VIEW OF GRATE SEAT**

NOTE TO CONTRACTOR  
 THE CONTRACTOR HAS THE OPTION OF FURNISHING EITHER DUCTILE IRON OR MALLEABLE IRON GRATE CASTINGS AND WELDED STEEL (ANGLE) GRATE SEATS AS DETAILED ON THIS SHEET OR WELDED STEEL GRATE AND WELDED STEEL GRATE SEAT AS DETAILED ON SHEET NO. 2 OF THIS DRAWING.

NOT TO SCALE

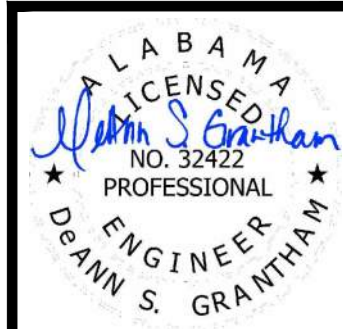

DESIGNED BY	DSG
DRAWN BY	JAC
DATE	JAN. 2024
CADD FILE	JACKSON RAA
PROJECT NO	2349101
REVISED	*
SHEET	25 OF 32

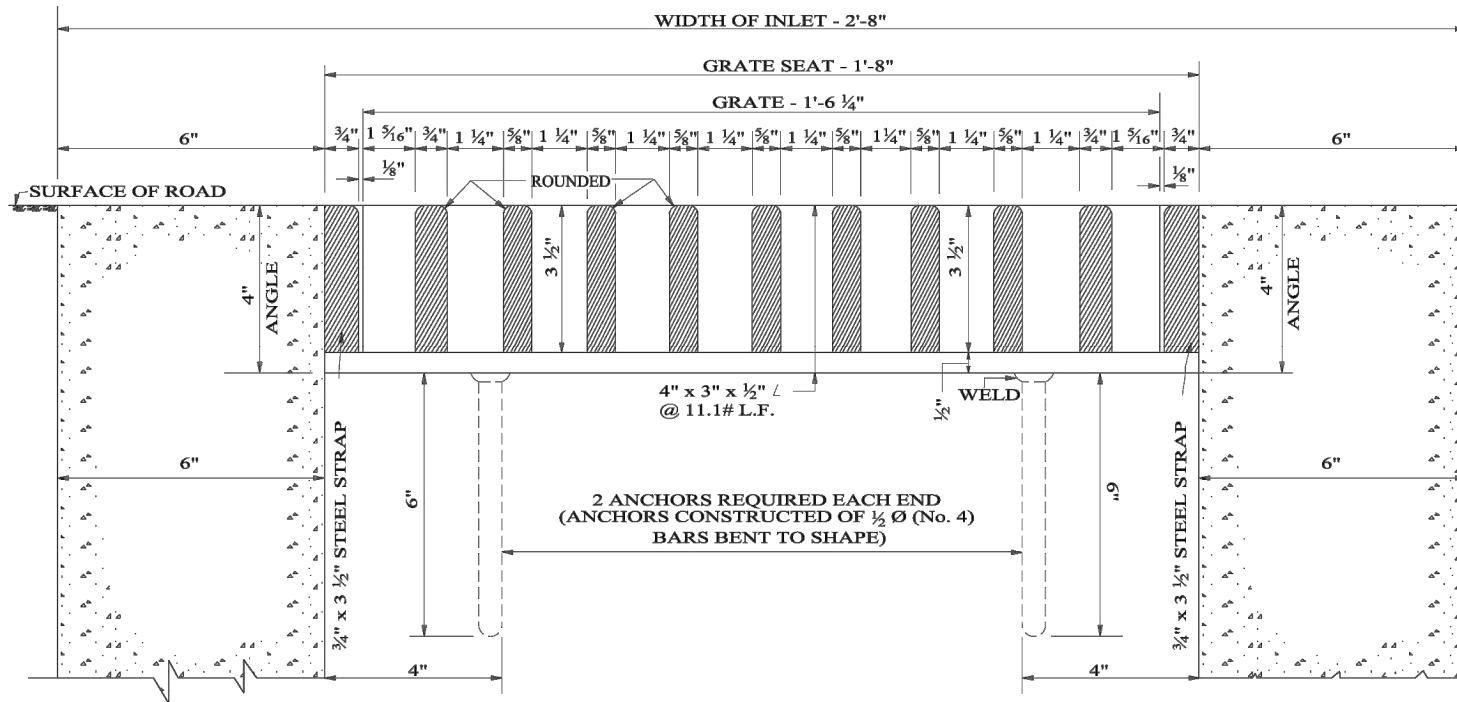

ENLARGED SECTION "AA"

WELDED STEEL GRATE

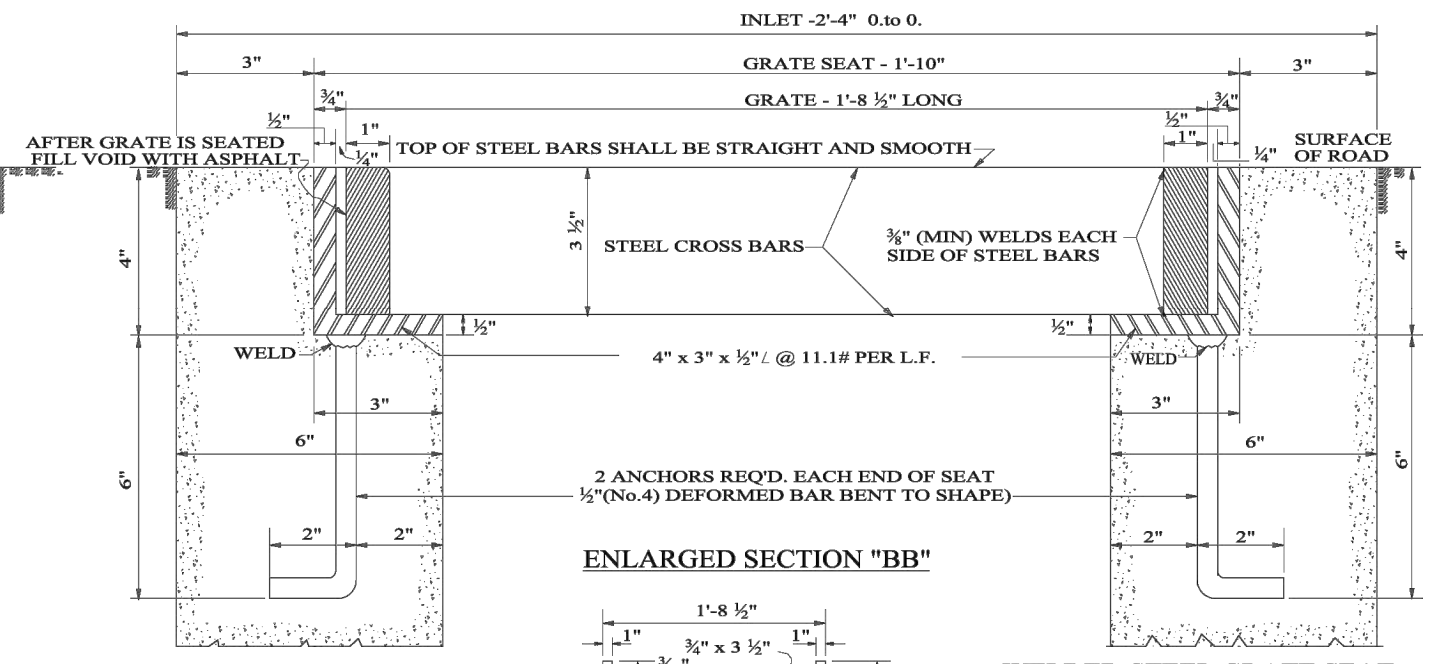

ENLARGED SECTION "BB"

WELDED STEEL GRATE SEAT

NOTE:  
JOIN CROSS BARS TO GRATE  
END STRAP WITH 3/8" (MINIMUM)  
WELDS ON EACH SIDE OF BARS.

FLOW ←

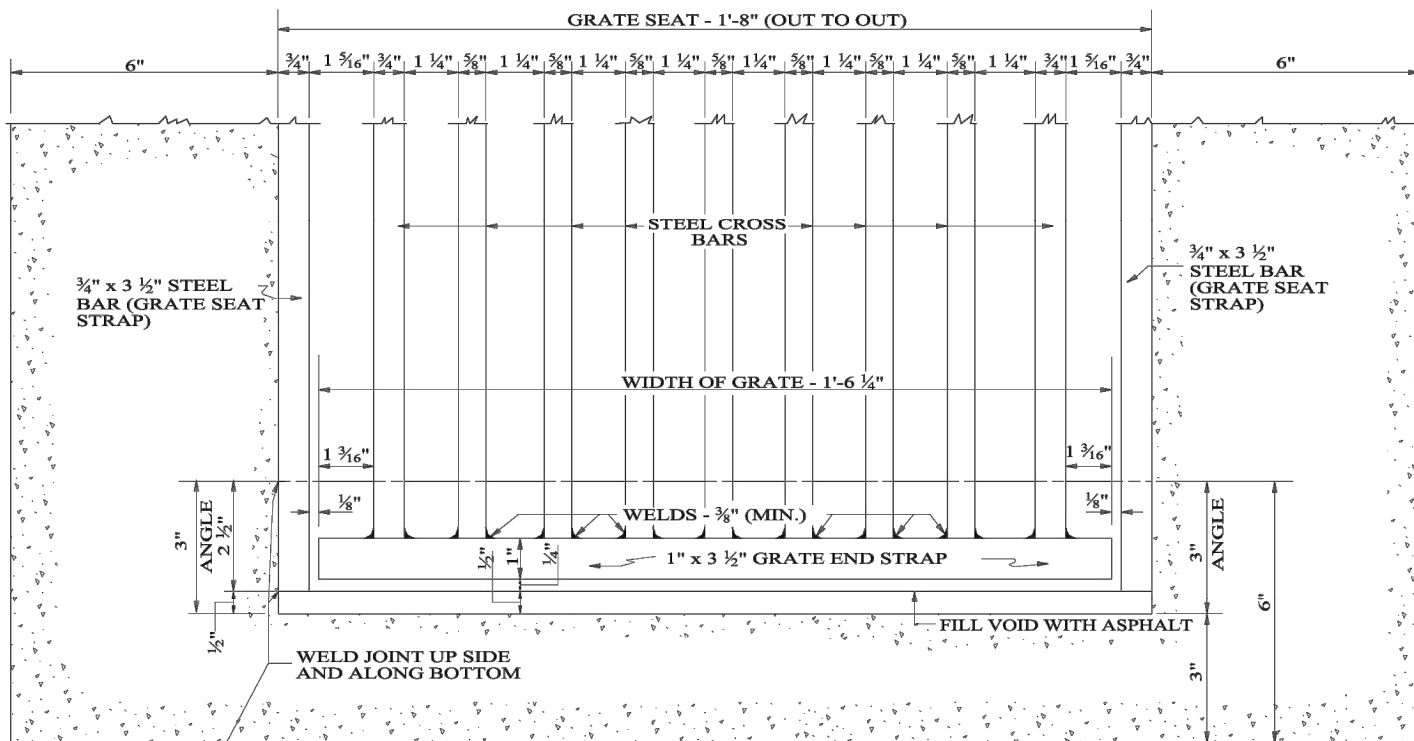

ENLARGED PART PLAN

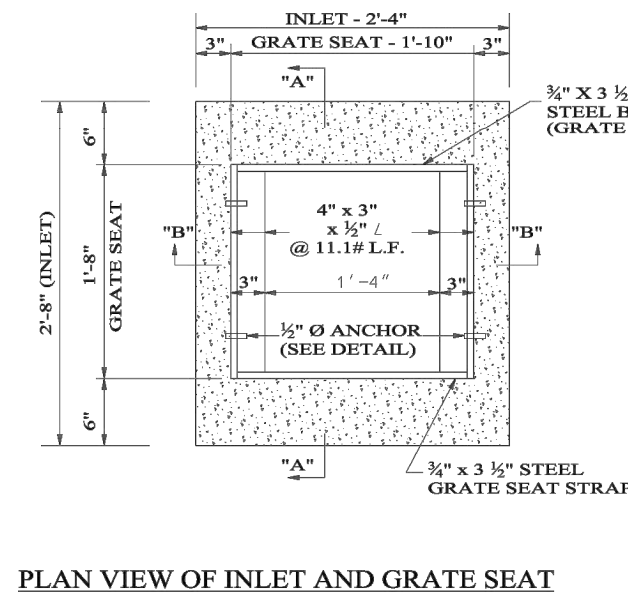

PLAN VIEW OF INLET AND GRATE SEAT

GENERAL NOTES

1. DROP INLET AND GRATE SHALL BE PLACED IN SUCH POSITION THAT BARS PARALLEL DIRECTION OF PRINCIPAL SURFACE FLOW.
2. WELDED STEEL GRATE AND WELDED STEEL GRATE SEAT SHALL BE IN ACCORDANCE WITH ALDOT SPECIFICATIONS SECTION 836.
3. INLET CONCRETE SHALL BE POURED WITH GRATE SEAT IN PLACE. CARE SHALL BE TAKEN THAT THE GRATE SEAT STRAPS ARE SECURED IN A STRAIGHT AND RIGID POSITION WHEN CONCRETE IS BEING POURED.
4. WELDED STEEL GRATE AND WELDED STEEL GRATE SEATS, INCLUDING ANCHORS SHALL BE CLEANED AND GALVANIZED AFTER WELDING IS COMPLETE.

NOT TO SCALE



JANUARY 8, 2024

DESIGNED BY	DSG
DRAWN BY	JAC
DATE	JAN. 2024
CADD FILE	JACKSON RAA
PROJECT NO	2349101
REVISED	*
SHEET	26 OF 32

PROJECT DETAILS  
STREET RESURFACING & DRAINAGE REPAIRS  
JACKSON, ALABAMA

# EROSION CONTROL DETAILS

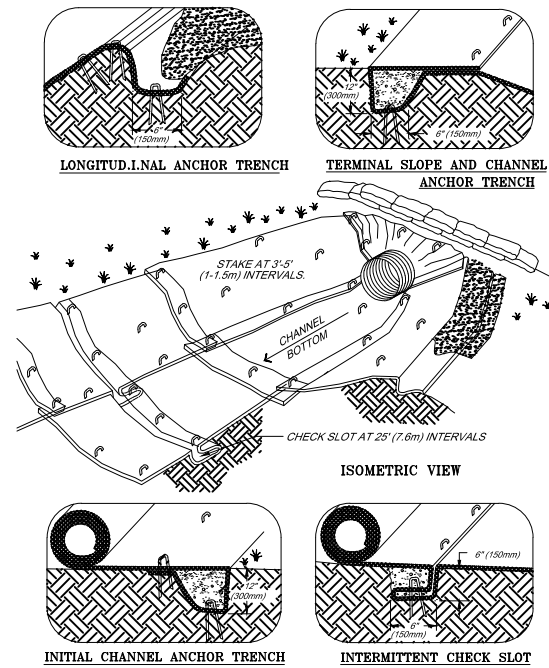

NOTES:  
1. CHECK SLOTS TO BE CONSTRUCTED PER MANUFACTURERS SPECIFICATIONS.  
2. STAKING OR STAPLING LAYOUT PER MANUFACTURERS SPECIFICATIONS.

**EROSION BLANKETS & TURF REINFORCEMENT MATS CHANNEL INSTALLATION**

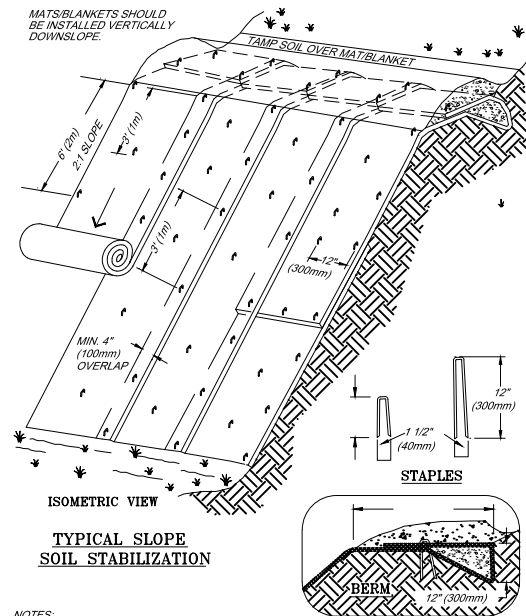

NOTES:  
1. SLOPE SURFACE SHALL BE FREE OF ROCKS, CLODS, STICKS AND GRASS. MATS/BLANKETS SHALL HAVE GOOD SOIL CONTACT.  
2. APPLY PERMANENT SEEDING BEFORE PLACING BLANKETS.  
3. LAY BLANKETS LOOSELY AND STAKE OR STAPLE TO MAINTAIN DIRECT CONTACT WITH THE SOIL. DO NOT STRETCH.

**EROSION BLANKETS & TURF REINFORCEMENT MATS SLOPE INSTALLATION**

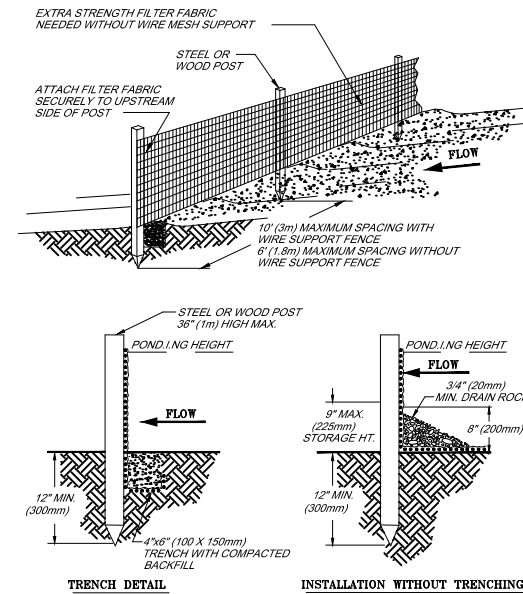

NOTES:  
1. SILT FENCE SHALL BE PLACED ON SLOPE CONTOURS TO MAXIMIZE PONDING EFFICIENCY.  
2. INSPECT AND REPAIR FENCE AFTER EACH STORM EVENT AND REMOVE SEDIMENT WHEN NECESSARY. 9" (225mm) MAXIMUM RECOMMENDED STORAGE HEIGHT.  
3. REMOVED SEDIMENT SHALL BE DEPOSITED TO AN AREA THAT WILL NOT CONTRIBUTE SEDIMENT OFF-SITE AND CAN BE PERMANENTLY STABILIZED.

**SILT FENCE**

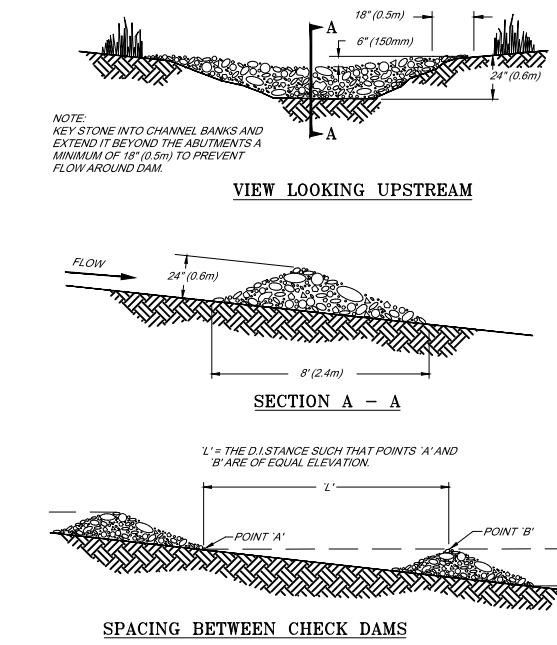

**ROCK CHECK DAM**

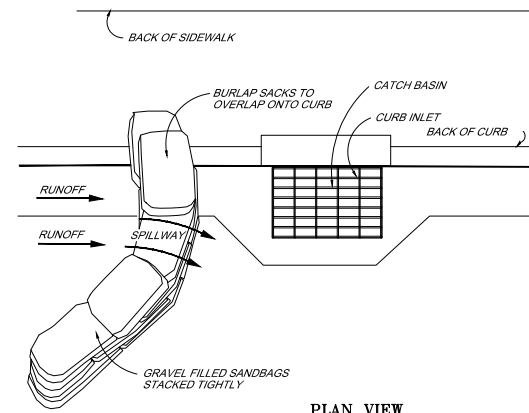

NOTES:  
1. PLACE CURB TYPE SEDIMENT BARRIERS ON GENTLY SLOPING STREET SEGMENTS WHERE WATER CAN POND AND ALLOW SEDIMENT TO SEPARATE FROM RUNOFF.  
2. SANDBAGS OF EITHER BURLAP OR WOVEN GEOTEXTILE FABRIC ARE FILLED WITH GRAVEL, LAYERED AND PACKED TIGHTLY.  
3. LEAVE A ONE SANDBAG GAP IN THE TOP ROW TO PROVIDE A SPILLWAY FOR OVERFLOW.  
4. INSPECT BARRIERS AND REMOVE SEDIMENT AFTER EACH STORM EVENT. SEDIMENT AND GRAVEL MUST BE REMOVED FROM THE TRAVELED WAY IMMEDIATELY.

**CURB AND GUTTER SEDIMENT BARRIER**

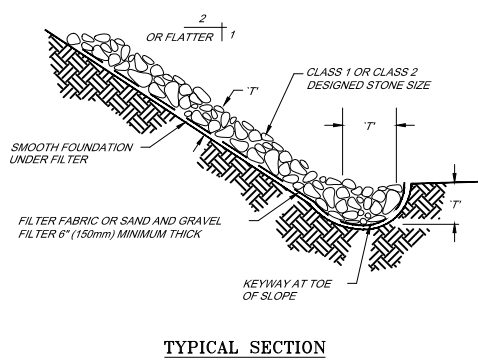

NOTE:  
"T" = THICKNESS. THICKNESS SHALL BE DETERMINED BY THE ENGINEER. MINIMUM THICKNESS SHALL BE 1.5x THE MAXIMUM STONE DIAMETER, NEVER LESS THAN 6" (150mm).

**RIPRAP PROTECTION**

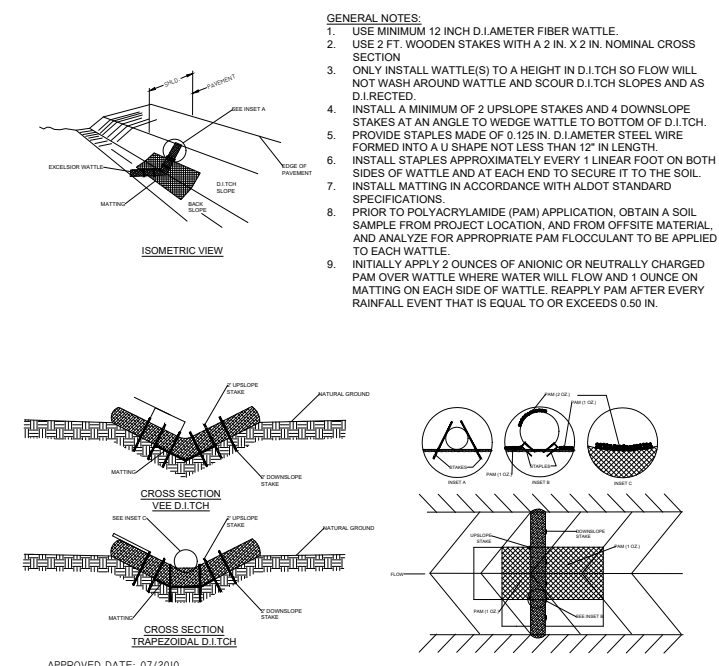

**TEMPORARY WATTLE CHECK DAM WITH MATTING AND OPTIONAL PAM**

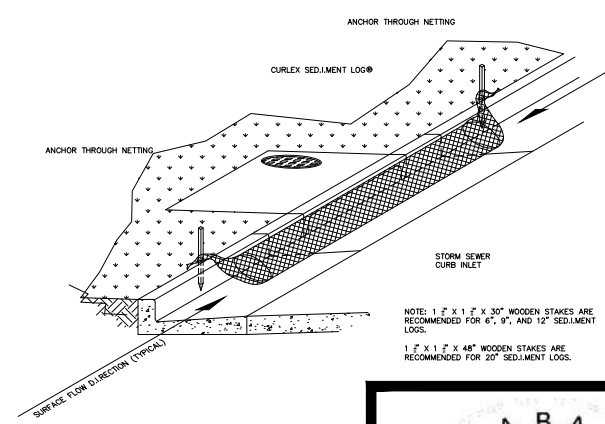

ALABAMA  
LICENSED  
DEANN S. GRANTHAM  
ENGINEER  
NO. 32422  
PROFESSIONAL

JANUARY 8, 2024

DESIGNED BY DSG  
DRAWN BY JAC  
DATE JAN. 2024  
CADD FILE JACKSON RAA  
PROJECT NO 2349101  
REVISED \*  
SHEET 27 OF 32



# TEMPORARY TRAFFIC CONTROL PLAN SHEET

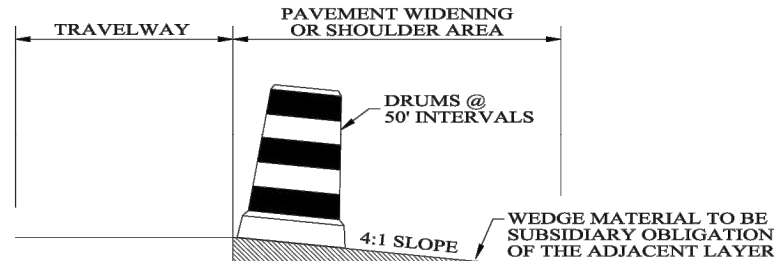

(FOR USE WHERE EXCAVATION HAS BEEN DONE, BUT WIDENING IS NOT COMPLETED BY NIGHTFALL OR WHERE PAVEMENT DROP OFF OF RESURFACING PROJECTS IS 3" OR MORE AT NIGHTFALL)

### TYPICAL FOR DROP-OFF AT EDGE OF PAVEMENT

NOTE:  
THE CONTRACTOR IS TO CONSTRUCT A WEDGE OF UNCLASSIFIED EXCAVATION OR CRUSHED AGGREGATE BASE. THE COST OF PLACING AND REMOVAL SHALL BE A SUBSIDIARY OBLIGATION OF THE ADJACENT LAYER.

CHANNELIZING DRUMS SHALL BE PLACED AT 50 FT INTERVALS.

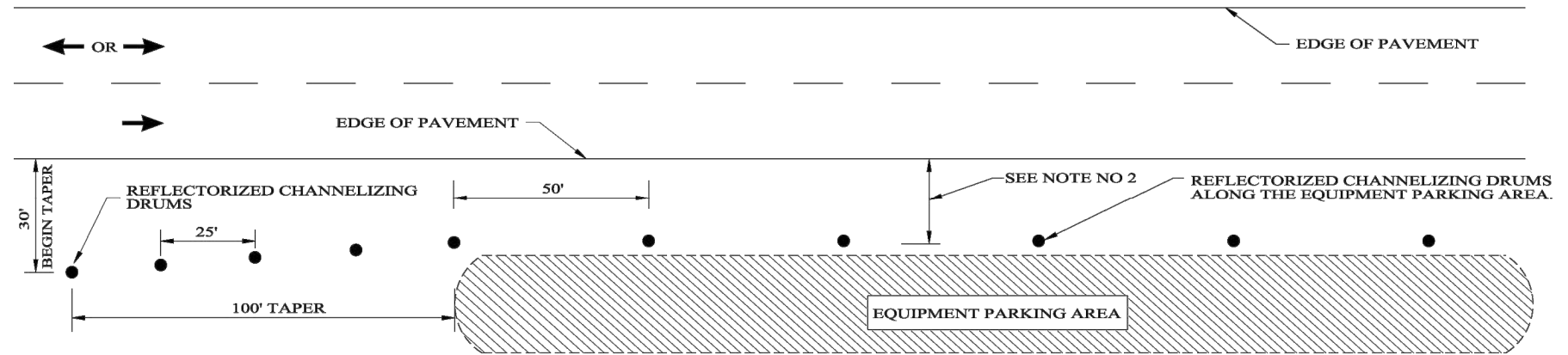

### NOTES:

1. SEE ALDOT'S GENERAL TRAFFIC CONTROL PLAN NOTE NO. 702.
2. DRUMS TO BE AS FAR AS PRACTICAL FROM EDGE OF PAVEMENT, MINIMUM DESIRABLE DISTANCE IS 15 FEET FOR FREEWAY TYPE FACILITIES AND 10 FEET FOR OTHER FACILITIES. FOR UNUSUAL CONDITIONS, SUCH AS SPECIAL EQUIPMENT OR LIMITED AVAILABLE SPACE, DIMENSIONS LESS THAN DESIRABLE SHALL BE AS DIRECTED BY THE ENGINEER.
3. ALL DEVICES TO BE FURNISHED BY THE CONTRACTOR WITHOUT COST TO THE ALDOT.

### DELINEATING DETAIL FOR EQUIPMENT PARKING OR STORING AREA

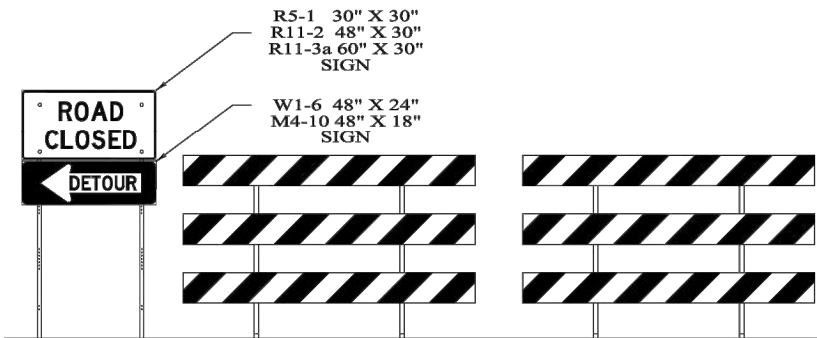

DETAILS FOR TYPICAL PLACEMENT OF TYPE III BARRICADES INSIDE OF CLEAR ZONE

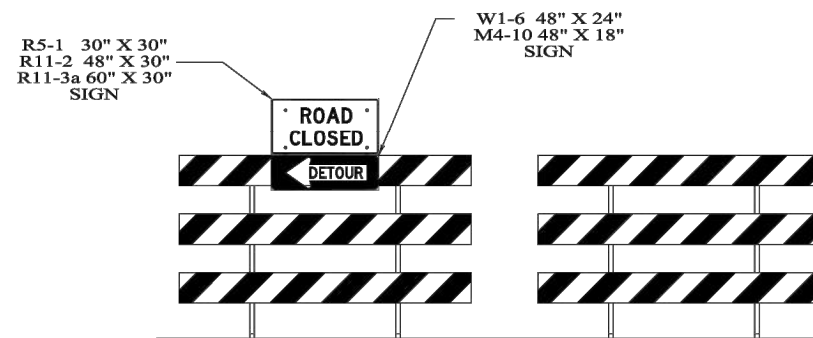

DETAILS FOR TYPICAL PLACEMENT OF TYPE III BARRICADES OUTSIDE OF CLEAR ZONE

### NOTES

1. SLOPE OF STRIPES ON BARRICADES SHALL BE IN ACCORDANCE WITH SECTION 6F.68 OF THE MUTCD AND DRAWING B-107-2.
2. IF SIGNS ARE REQUIRED TO BE USED IN CONJUNCTION WITH TYPE III BARRICADES TO BE PLACED INSIDE THE CLEAR ZONE, THEY SHALL BE POST MOUNTED TO THE SIDE OF THE BARRICADES AS SHOWN.
3. IF ROAD CLOSED OR DETOUR SIGNS ARE REQUIRED TO BE USED WITH TYPE III BARRICADES TO BE PLACED OUTSIDE THE CLEAR ZONE, THEY SHALL BE PLACED ON THE TOP OF THE BARRICADES NEAREST THE DETOUR.

NOT TO SCALE



JANUARY 8, 2024

# TEMPORARY TRAFFIC CONTROL PLAN SHEET

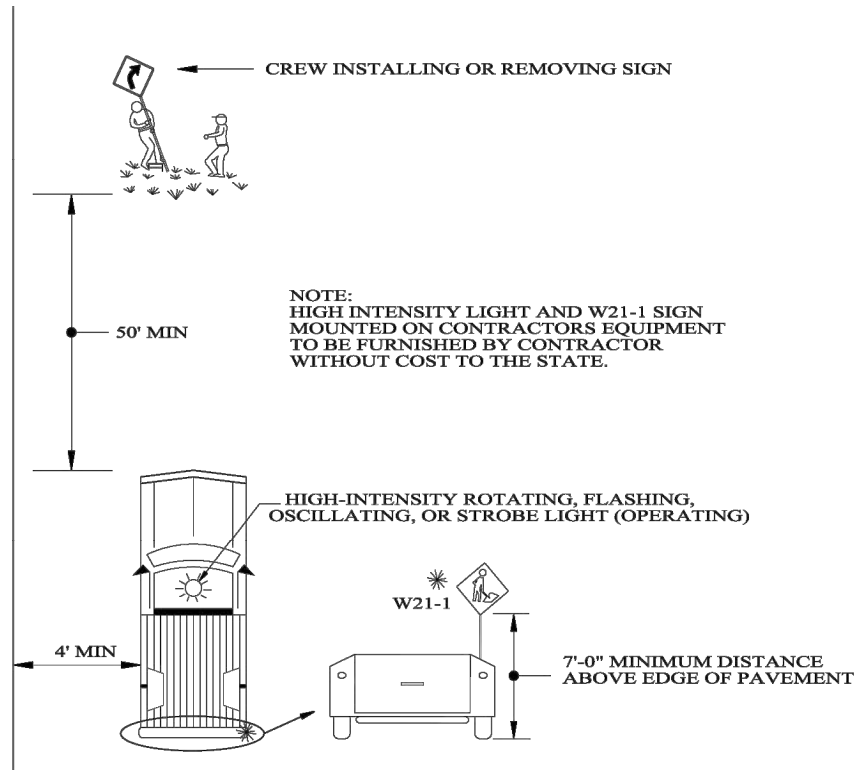

TYPICAL METHOD FOR INSTALLING OR REMOVING CONSTRUCTION SIGNS

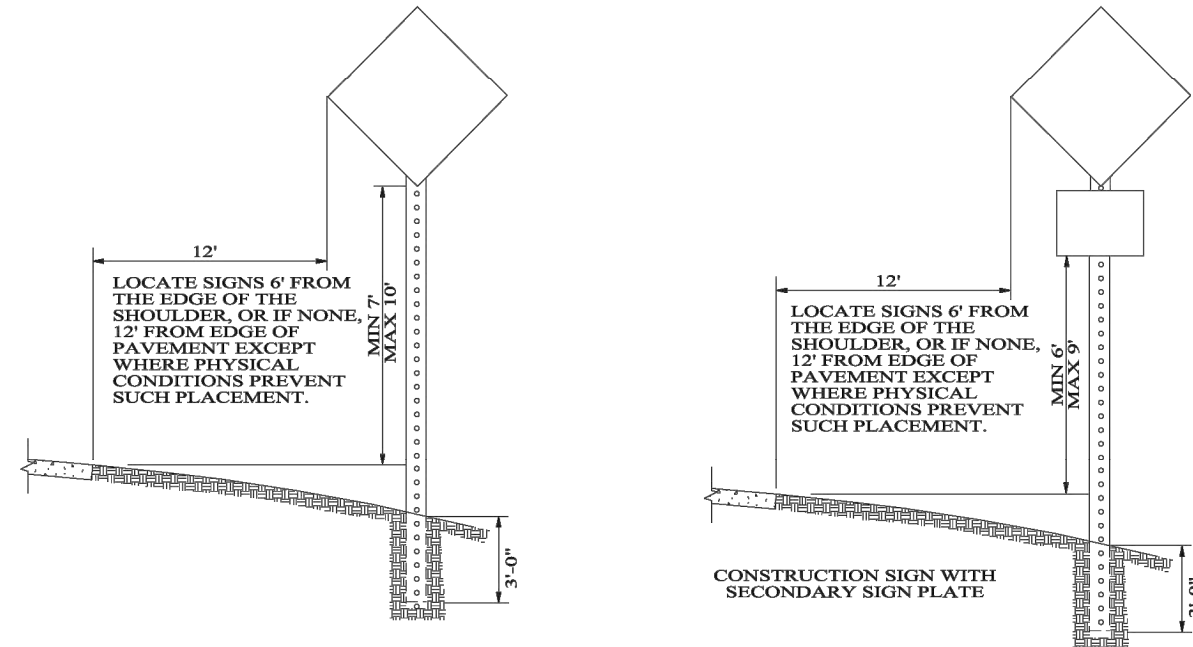

NOTE:  
IF THE CONTRACTOR CHOOSES TO SPLICE THE POSTS FOR THE REQUIRED POST MOUNTED CONSTRUCTION SIGNS, THEY SHALL BE SPLICED AS SHOWN ON DRAWING IHS-710-23.

HEIGHT AND LATERAL LOCATION OF POST MOUNTED CONSTRUCTION SIGNS

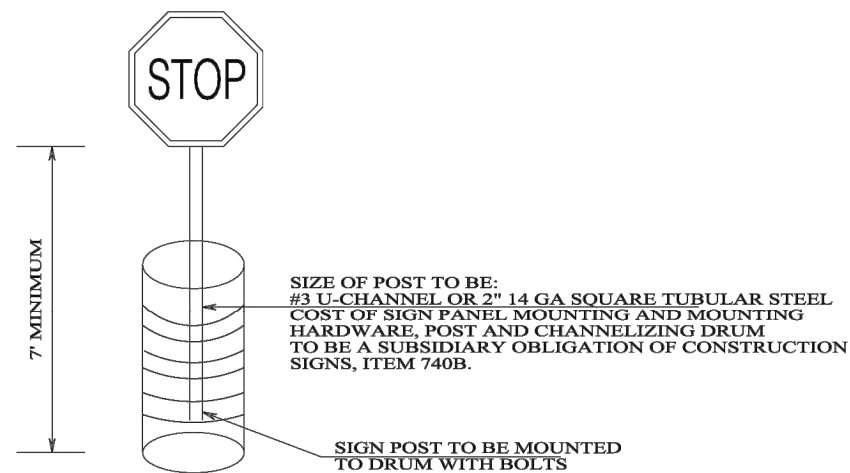

DETAIL FOR DRUM MOUNTED CONSTRUCTION SIGNS

NOT TO SCALE



JANUARY 8, 2024

# TEMPORARY TRAFFIC CONTROL PLAN SHEET

TYPICAL PLACEMENT  
FOR ADVANCE  
WARNING SIGNS

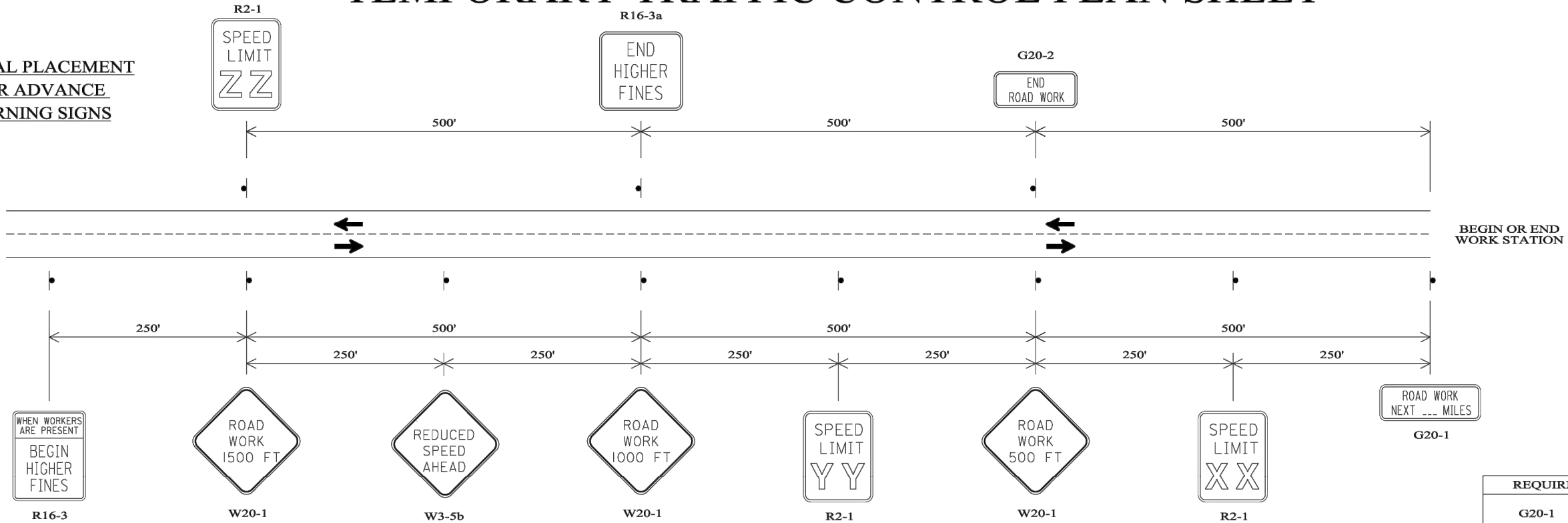

**GENERAL NOTES**

1. ALL ADVANCE WARNING SIGNS REQUIRED AT THE BEGINNING AND END OF PROJECT SHALL BE POST MOUNTED. ALL SIGNS REQUIRED FOR THE LANE CLOSURE SHALL BE TEMPORARY MOUNTED.
2. SIGN (XX) SHALL SHOW THE SPEED IN THE WORK ZONE. SIGN (YY) SHALL BE USED IF SPEED REDUCTION REQUIRES TWO SIGNS. SIGN(ZZ) SHALL SHOW THE POSTED SPEED OUTSIDE THE WORK ZONE.

REQUIRED SIGN SIZES	
G20-1	48" X 24"
G20-2	48" X 24"
R2-1	24" X 30"
W3-5b	48" X 48"
R16-3	48" X 60"
R16-3a	48" X 48"
W20-1	48" X 48"
W20-4	48" X 48"
W20-7	48" X 48"

THE SIGN SIZES SHOWN ON THIS SHEET SHALL SUPERCEDE THOSE SHOWN ON THE STANDARD HIGHWAY SIGNS DRAWINGS UNLESS OTHERWISE APPROVED BY THE ENGINEER.

**TRAFFIC CONTROL FOR INTERSECTING SIDE ROADS WITHIN WORK AREA**

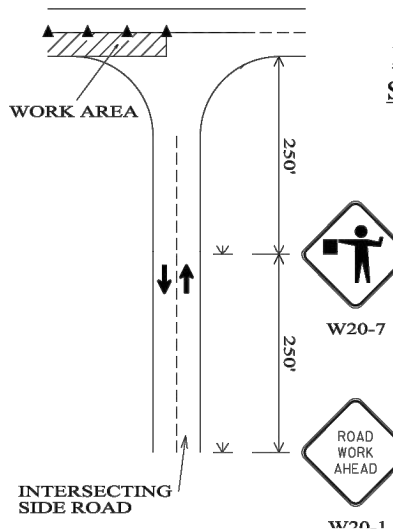

NOTE: THE W20-1 SIGN TO BE USED ON INTERSECTING ROADS SHALL BE 36"X36" IN SIZE. THE TEMPORARY MOUNTED W20-1 SIGN SHOWN ON THE SIDE ROAD, WILL NOT BE REQUIRED IF ONE IS ALREADY POST MOUNTED ON THE SIDE STREET.

SEE TABLE 6E-1 OF THE MUTCD PART 6 FOR DISTANCE OF FLAGGER STATION IN ADVANCE OF THE WORK AREA

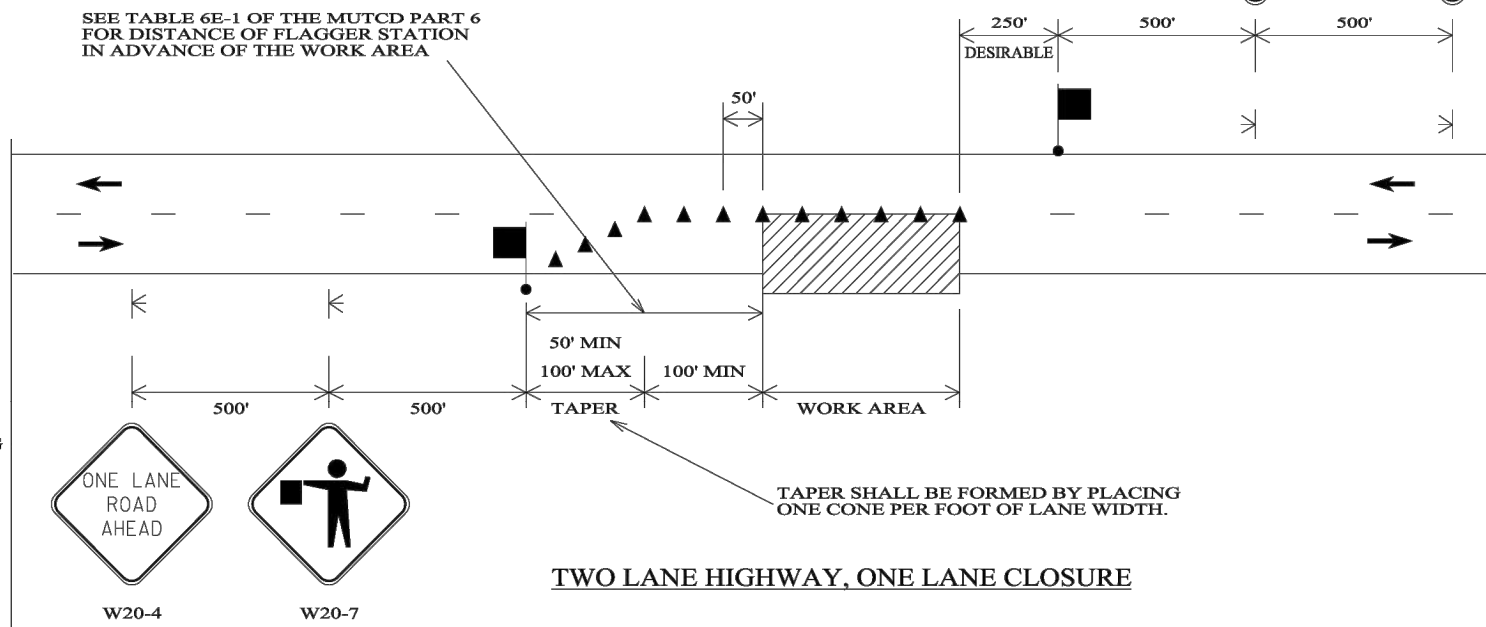

**TWO LANE HIGHWAY, ONE LANE CLOSURE**

TAPER SHALL BE FORMED BY PLACING ONE CONE PER FOOT OF LANE WIDTH.

**LEGEND**

- TEMPORARY MOUNTED SIGN
- POST MOUNTED SIGN
- CONES
- FLAGGER
- WORK AREA

NOT TO SCALE

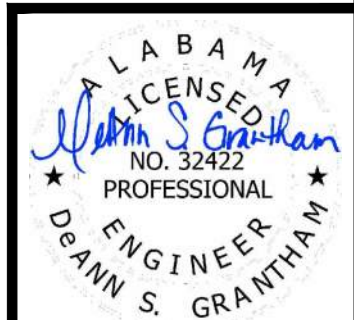

JANUARY 8, 2024

# TEMPORARY TRAFFIC CONTROL PLAN SHEET

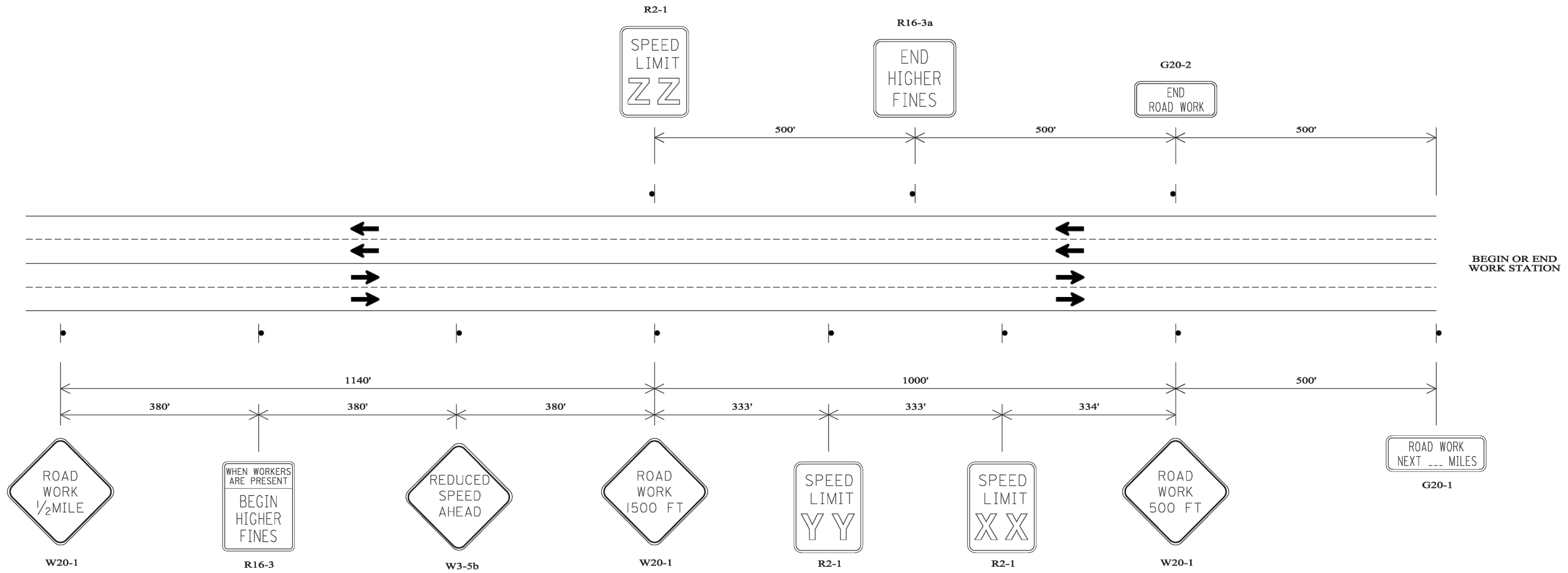

REQUIRED SIGN SIZES	
G20-1	48" X 24"
G20-2	48" X 24"
R2-1	30" X 36"
W3-5b	48" X 48"
R16-3	48" X 60"
R16-3a	48" X 48"
W20-1	48" X 48"

THE SIGN SIZES SHOWN ON THIS SHEET SHALL SUPERCEDE THOSE SHOWN ON THE STANDARD HIGHWAY SIGNS DRAWINGS UNLESS OTHERWISE APPROVED BY THE ENGINEER.

**GENERAL NOTES**

- ALL SIGNS SHALL BE POST MOUNTED AS SHOWN.
- SIGN (XX) SHALL SHOW THE SPEED IN THE WORK ZONE. SIGN (YY) SHALL BE USED IF SPEED REDUCTION REQUIRES TWO SIGNS. SIGN(ZZ) SHALL SHOW THE POSTED SPEED OUTSIDE THE WORK ZONE.

**LEGEND**  
 POST MOUNTED SIGN

NOT TO SCALE

ALABAMA  
 LICENSED  
 DEANN S. GRANTHAM  
 NO. 32422  
 PROFESSIONAL ENGINEER  
 JANUARY 8, 2024

DESIGNED BY	DSG
DRAWN BY	JAC
DATE	JAN. 2024
CADD FILE	JACKSON RAA
PROJECT NO	2349101
REVISED	*
SHEET	31 OF 32

# TEMPORARY TRAFFIC CONTROL PLAN SHEET

TYPICAL SCHEME FOR OUTSIDE LANE CLOSURE

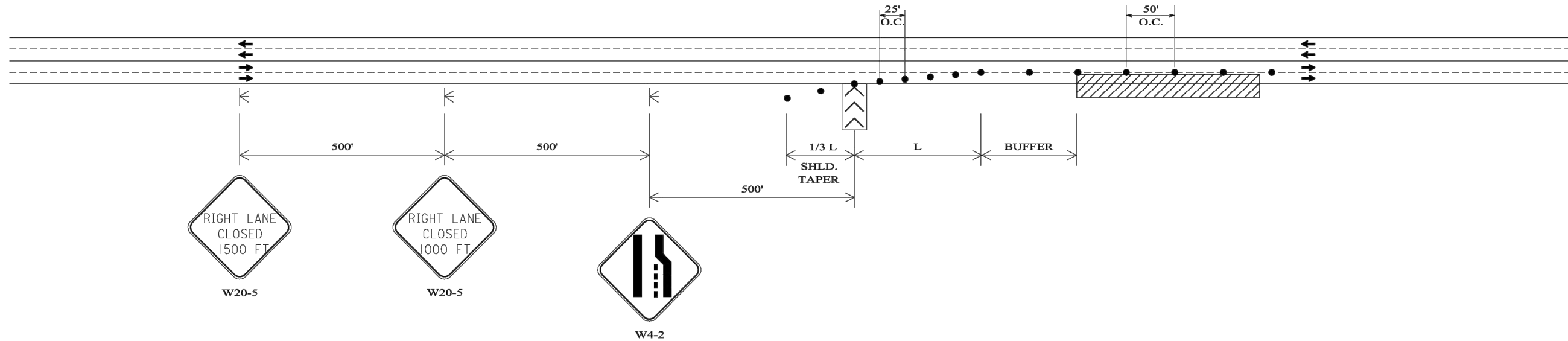

REQUIRED SIGN SIZES	
W4-2	48" X 48"
W20-5	48" X 48"

THE SIGN SIZES SHOWN ON THIS SHEET SHALL SUPERCEDE THOSE SHOWN ON THE STANDARD HIGHWAY SIGNS DRAWINGS UNLESS OTHERWISE APPROVED BY THE ENGINEER.

TYPICAL SCHEME FOR INSIDE LANE CLOSURE

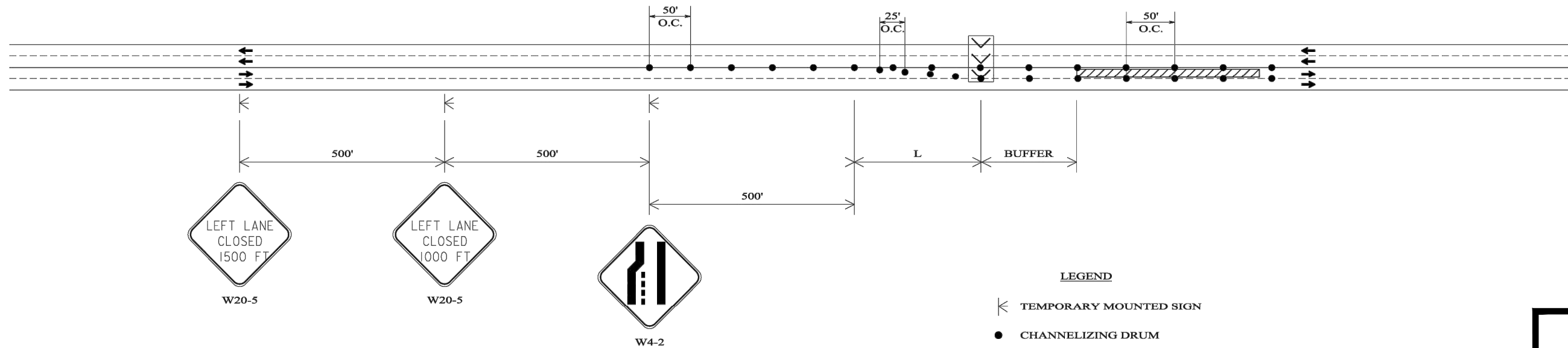

LEGEND

- TEMPORARY MOUNTED SIGN
- CHANNELIZING DRUM
- WORK AREA
- PORTABLE SEQUENTIAL ARROW AND CHEVRON SIGN UNIT

GENERAL NOTES

- ALL SIGNS SHALL BE TEMPORARY MOUNTED AS SHOWN, UNLESS THE WORK PERIOD EXCEEDS FOUR (4) DAYS. IN SUCH CASES, THE SIGNS SHALL BE POST MOUNTED.

NOT TO SCALE

ALABAMA  
LICENSED  
*Deann S. Grantham*  
NO. 32422  
PROFESSIONAL  
ENGINEER  
DEANN S. GRANTHAM

JANUARY 8, 2024

DESIGNED BY	DSG
DRAWN BY	JAC
DATE	JAN. 2024
CADD FILE	JACKSON RAA
PROJECT NO	2349101
REVISED	*
SHEET	32 OF 32

TRAFFIC CONTROL PLAN  
STREET RESURFACING & DRAINAGE REPAIRS  
JACKSON, ALABAMA